

COLORING

DURING THE WAR THE DIFFERENT SQUADRONS COLORED THEIR SPADS TO THEIR OWN TASTE.

A POPULAR COMBINATION TO GIVE A COMOUFLAGE EFFECT IS TO PAINT RED ALL OVER AND THEN ADD SPOCHES OF GREEN ALL OVER.

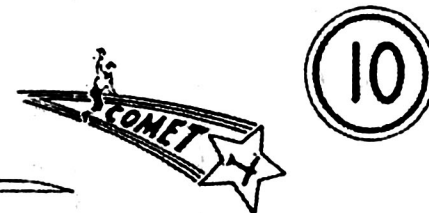
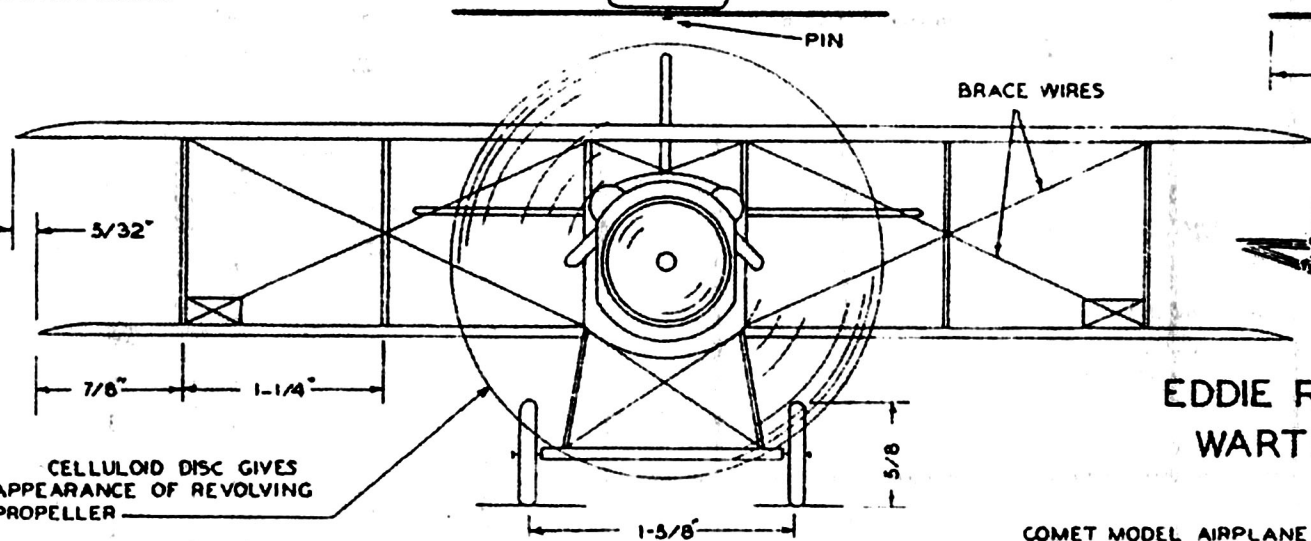
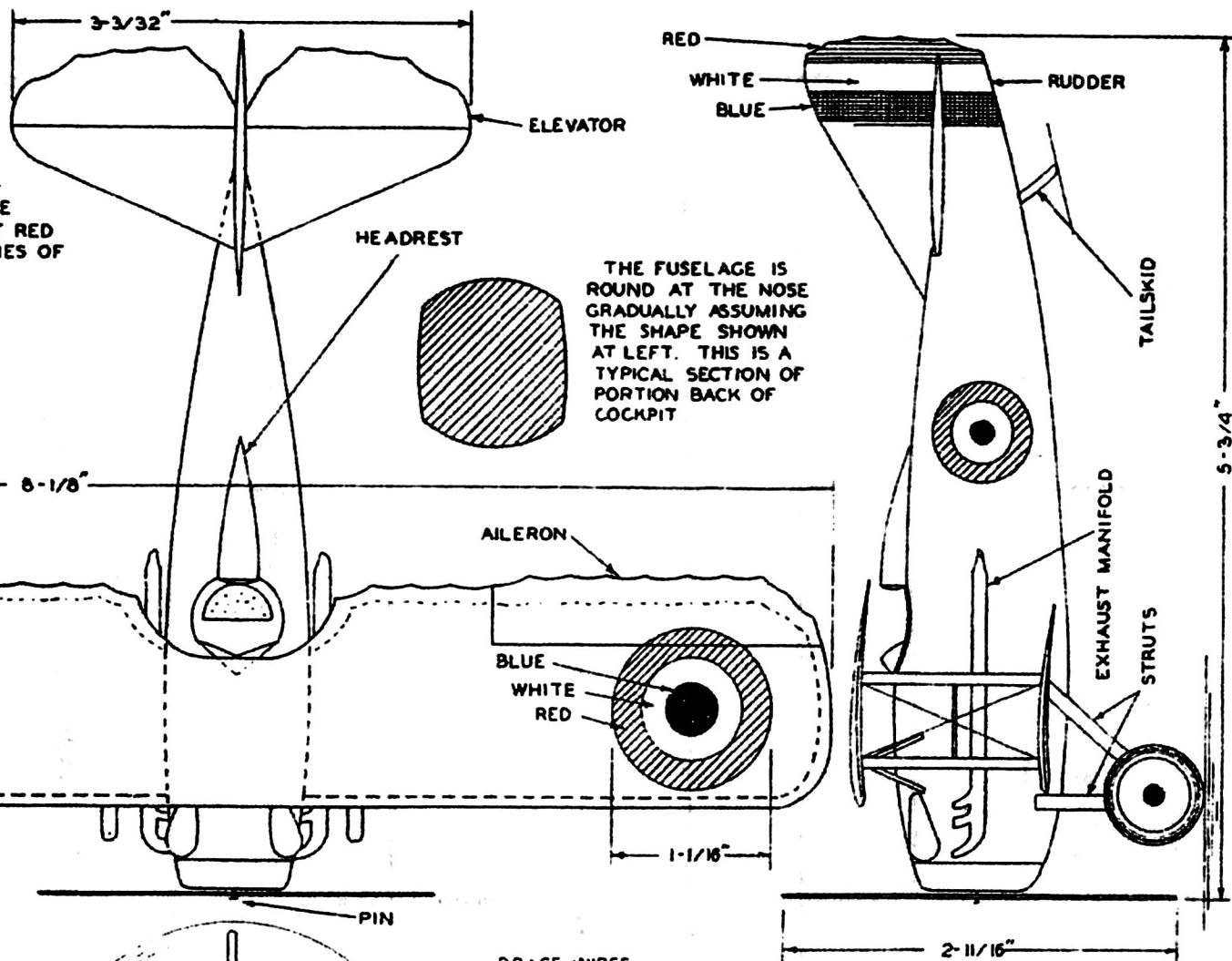

EDDIE RICKENBACKER'S
WARTIME SPAD