

Steps Towards Knowledgeable Neuroprostheses

Patrick Pilarski

*Division of Physical Medicine & Rehabilitation, BLINC Lab,
Alberta Innovates Centre for Machine Learning, and
Reinforcement Learning and Artificial Intelligence Laboratory*

(and with Sherstan, Machado, White)



Steps Towards **Knowledgeable** Neuroprostheses

Patrick Pilarski

*Division of Physical Medicine & Rehabilitation, BLINC Lab,
Alberta Innovates Centre for Machine Learning, and
Reinforcement Learning and Artificial Intelligence Laboratory*

(and with Sherstan, Machado, White)



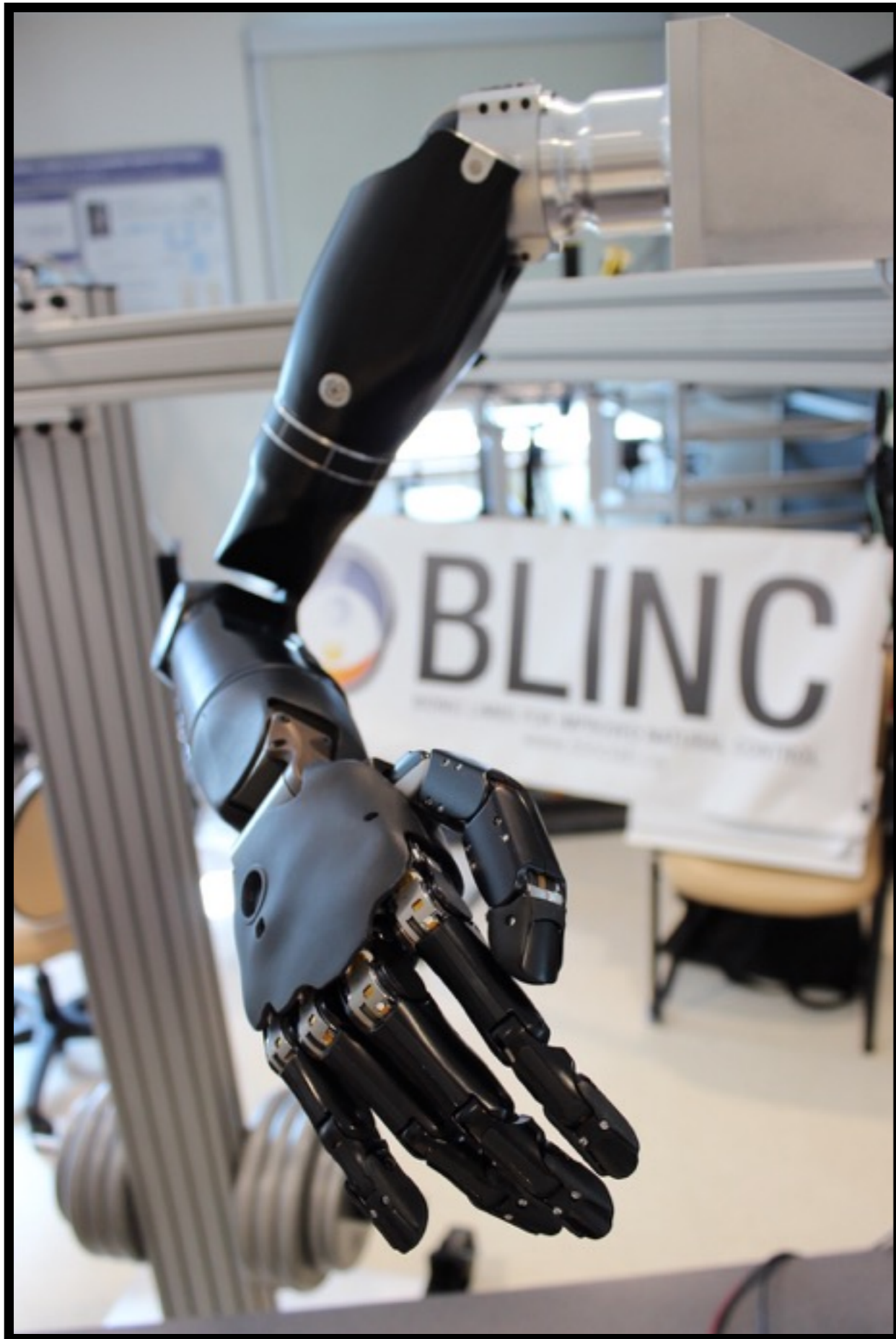

Modular Prosthetic Limb (MPL):

22-DOF robot arm.

100+ sensory percepts.

Real-time data stream.

Multiple human-machine
interface approaches:
EMG, data glove, etc.

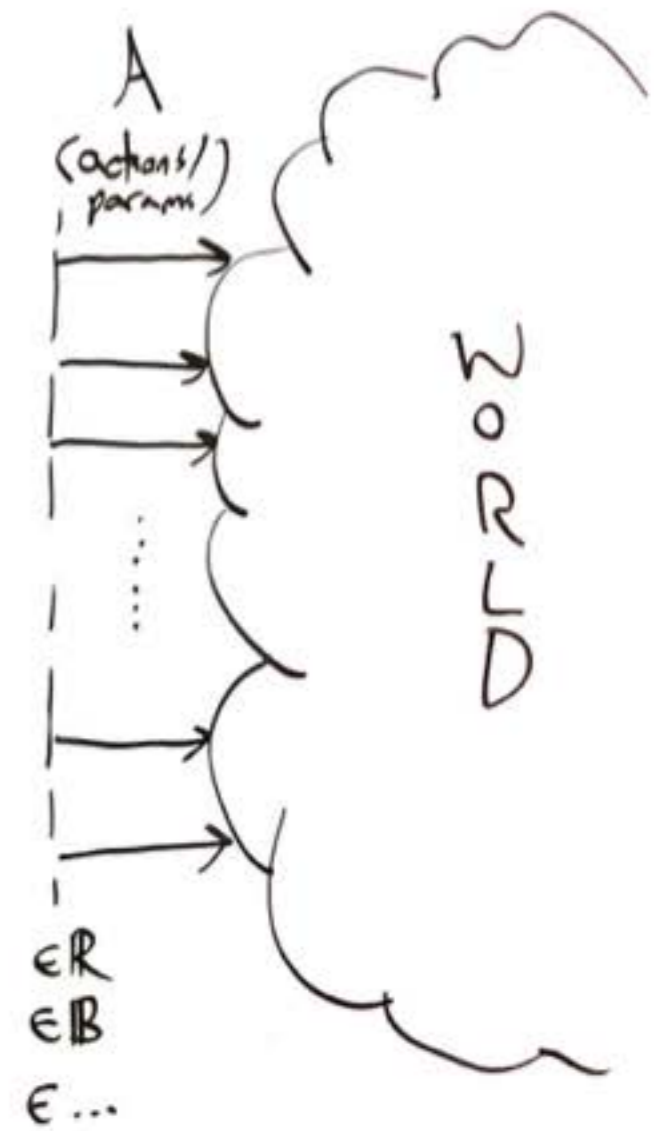
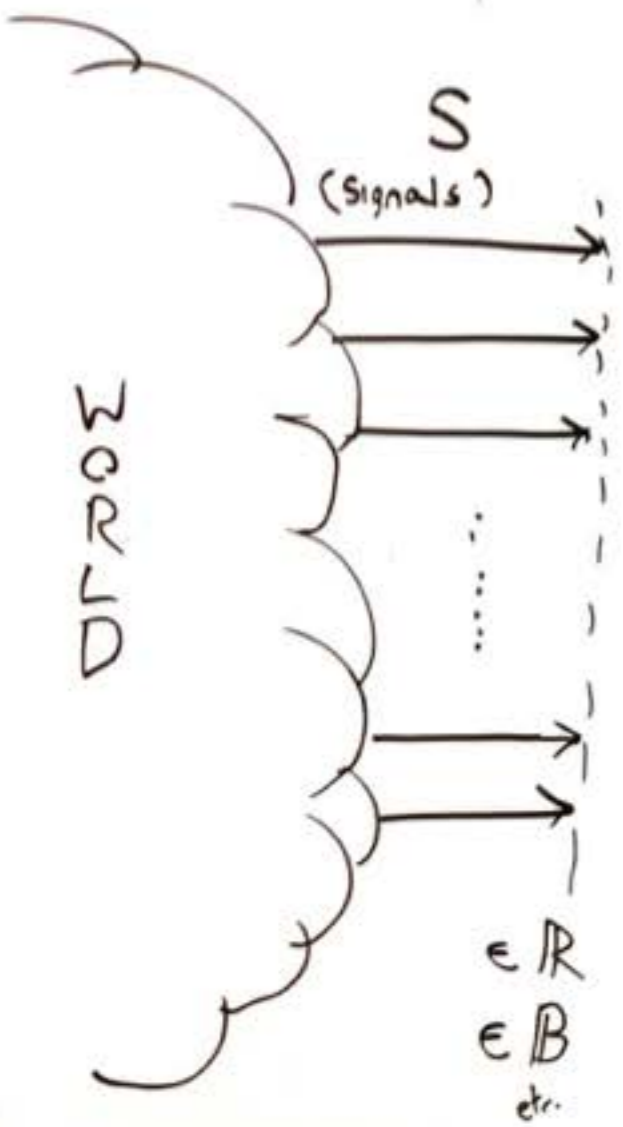

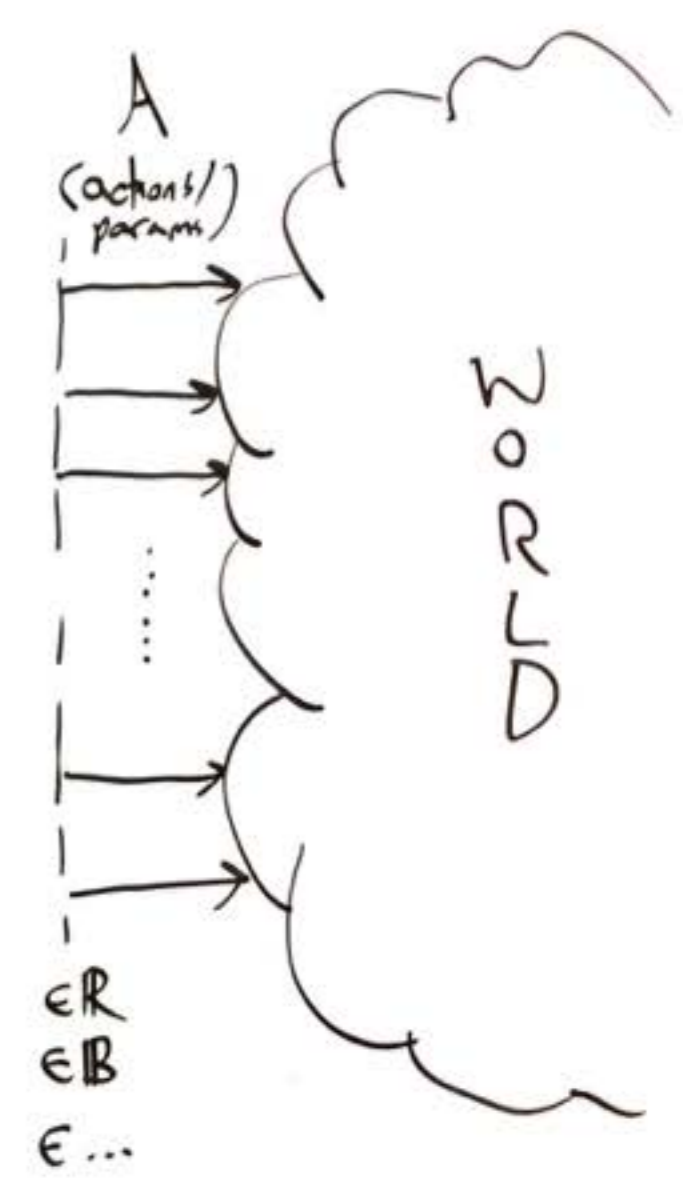
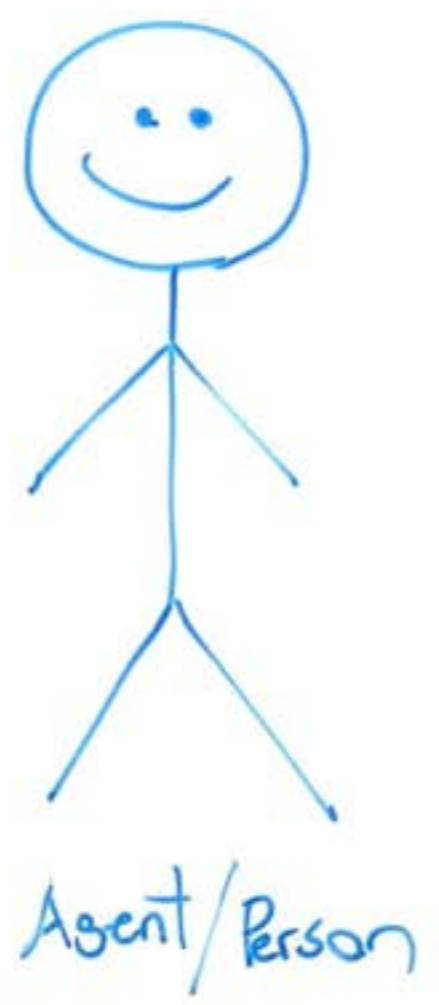
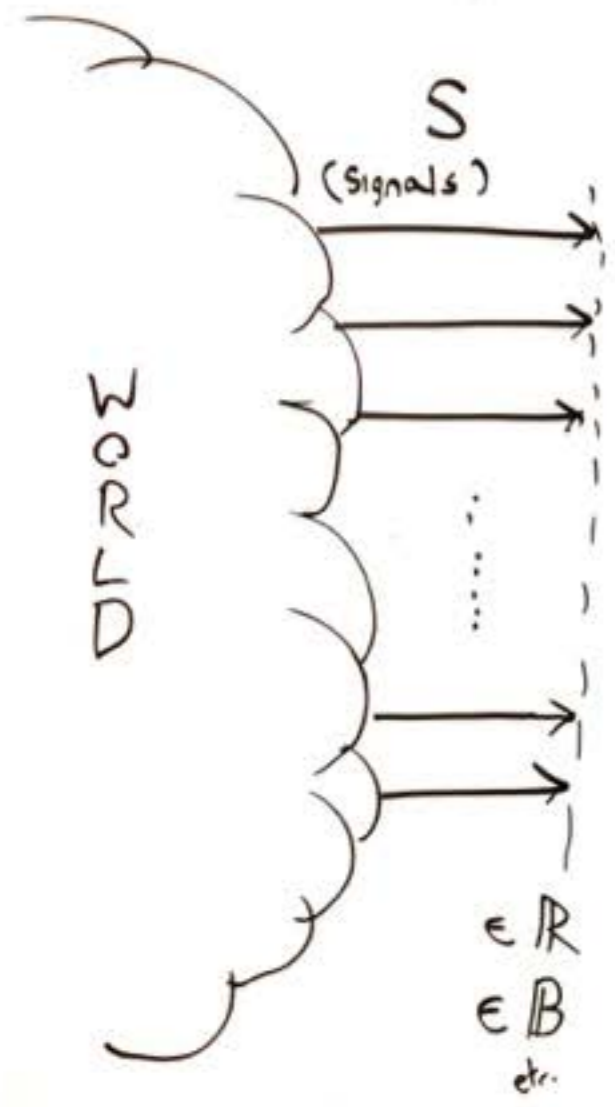

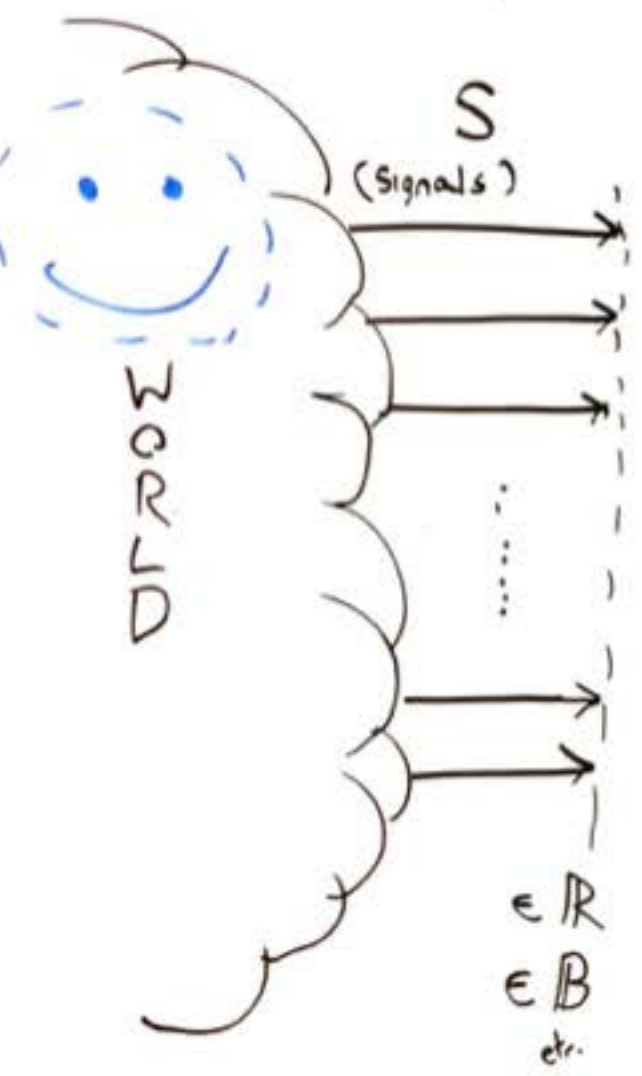

Agent/Person

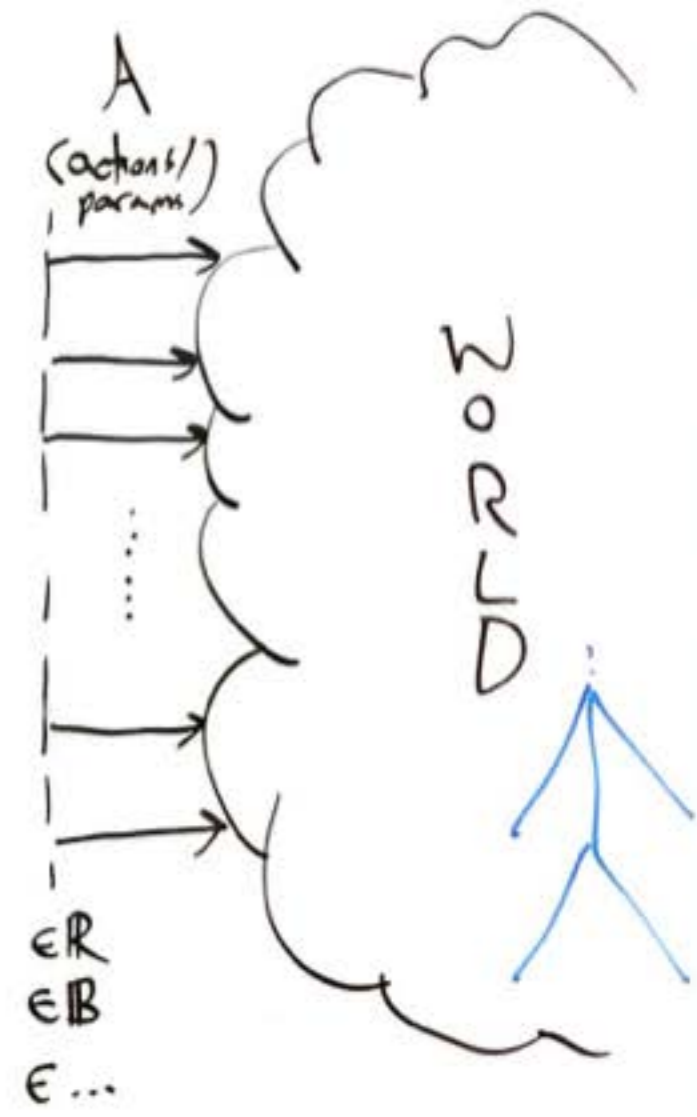

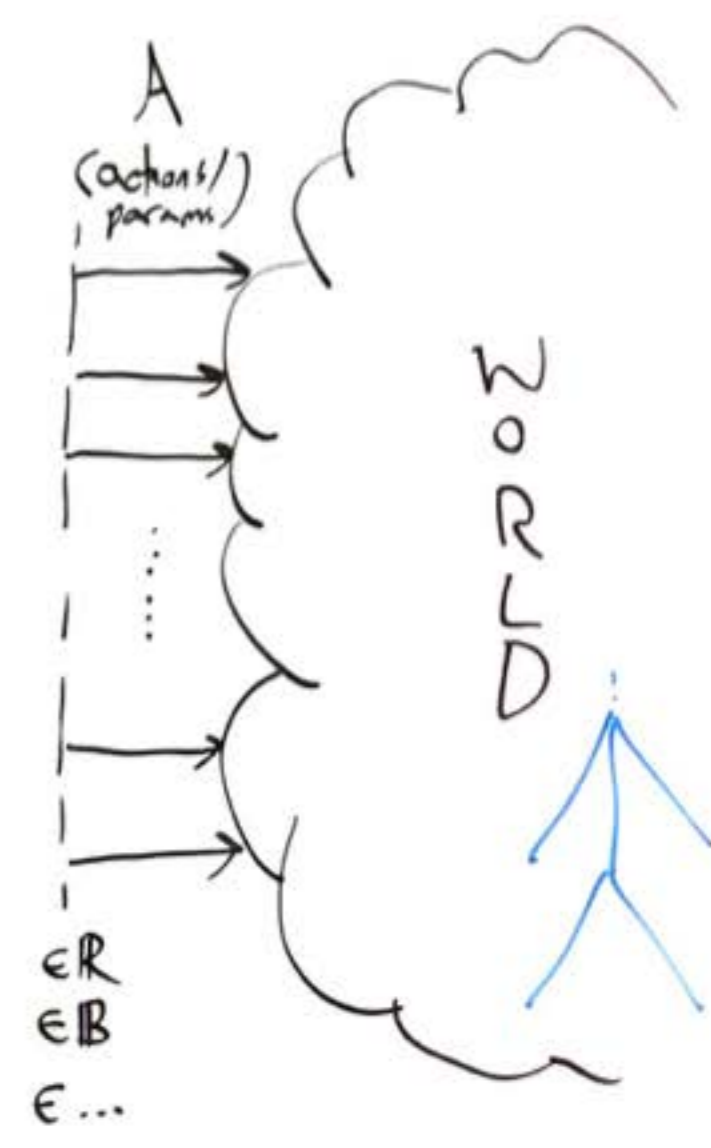
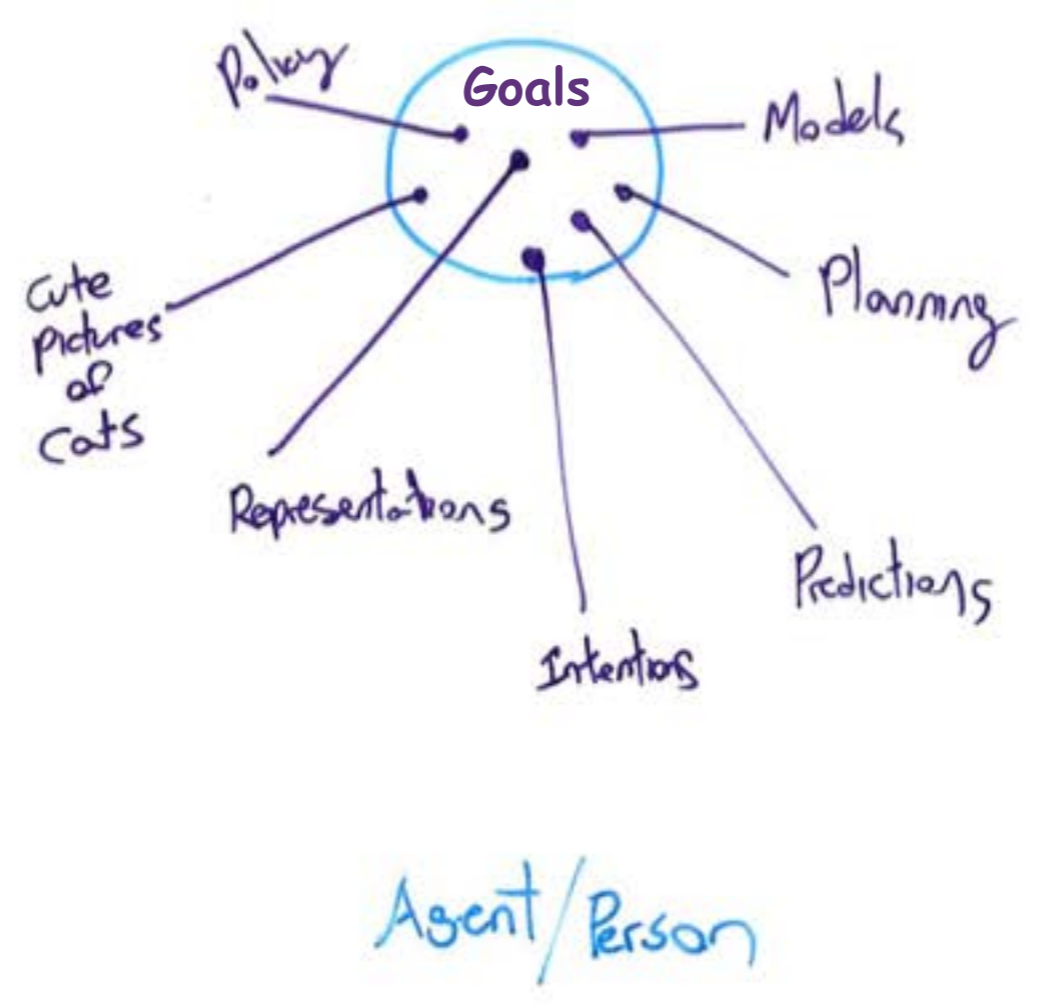
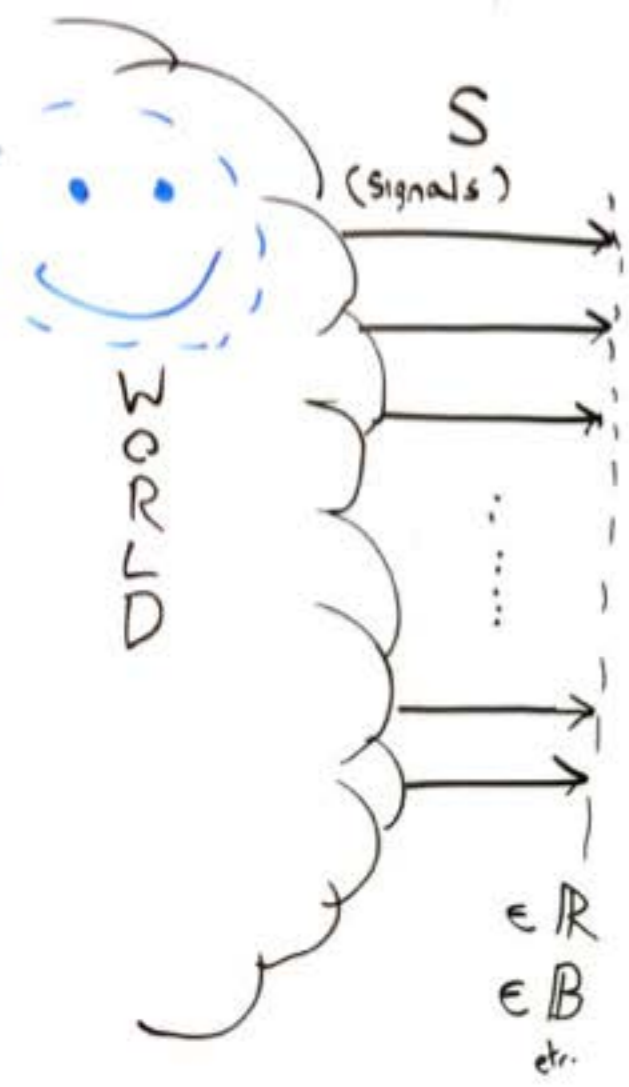

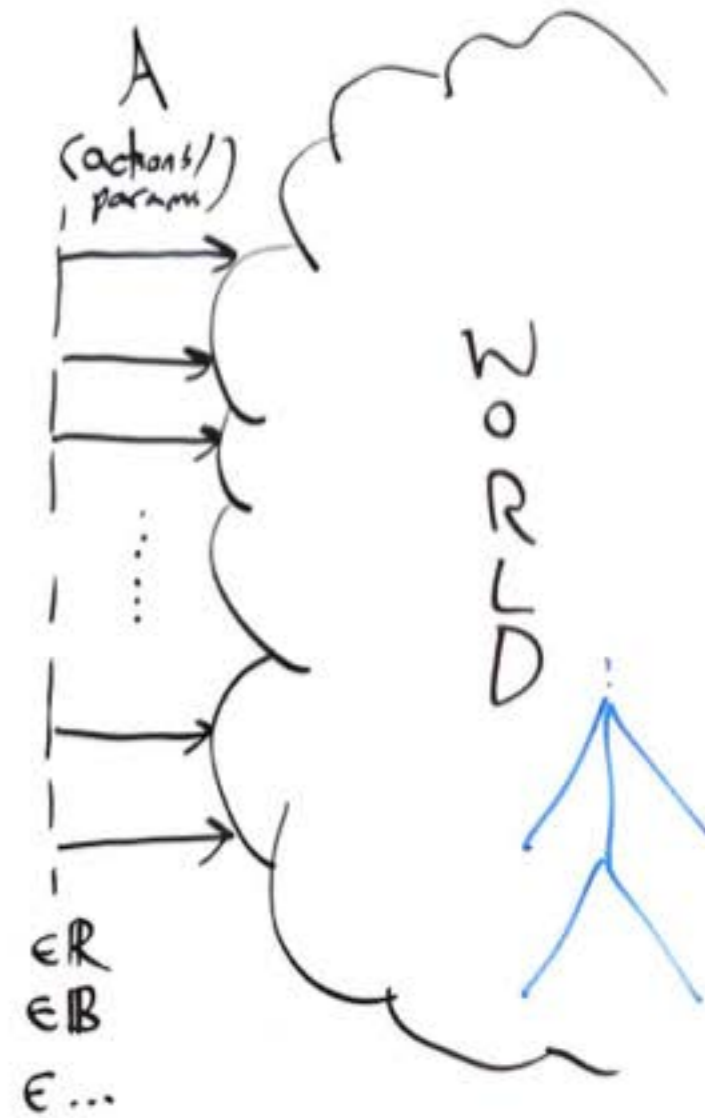
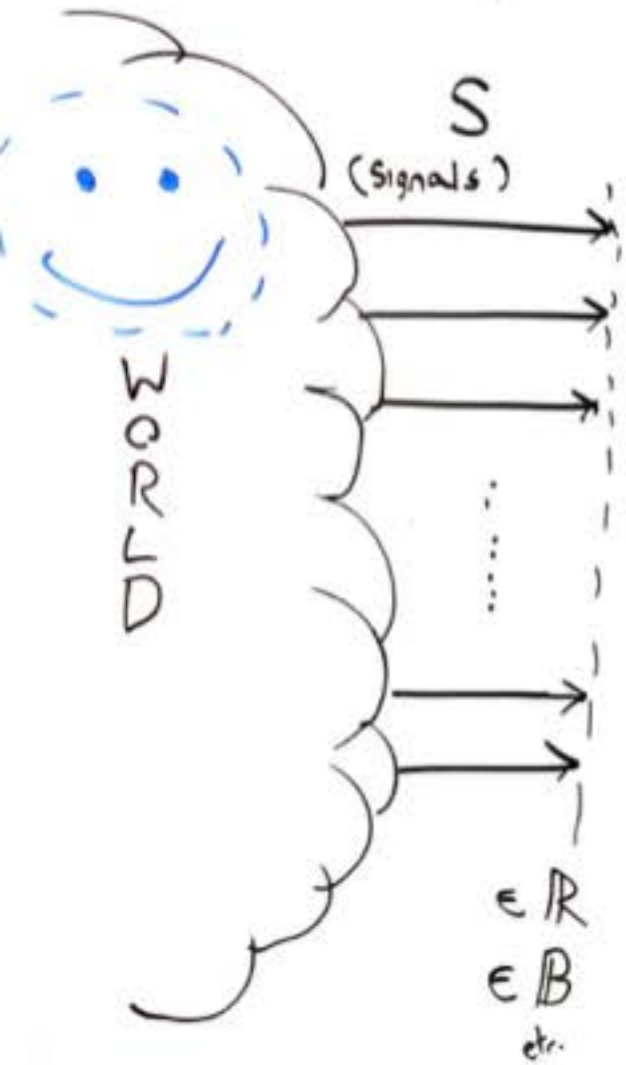

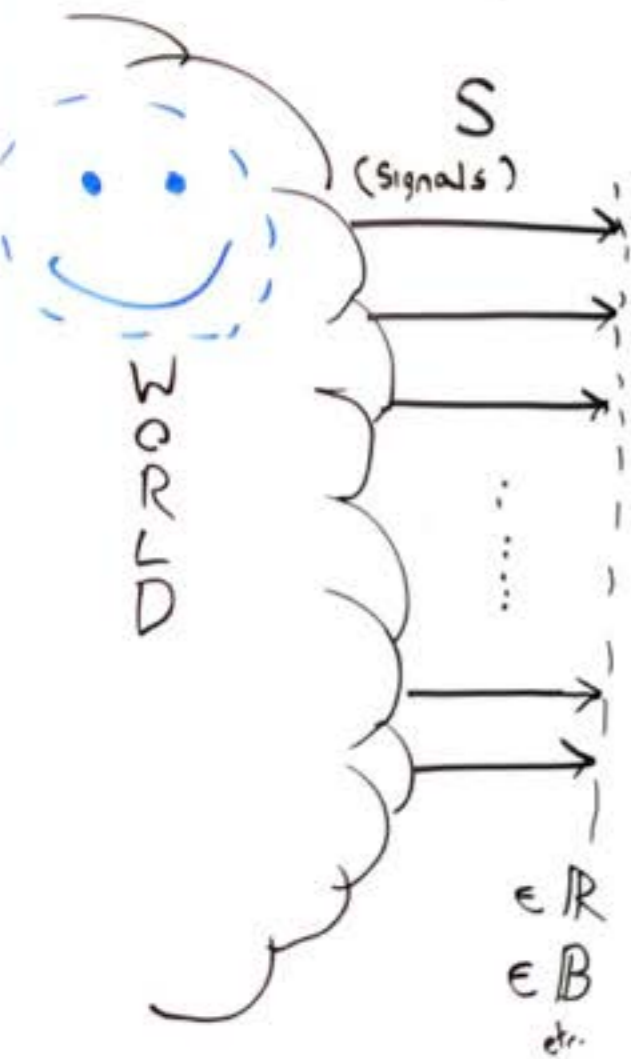

KNOWLEDGE

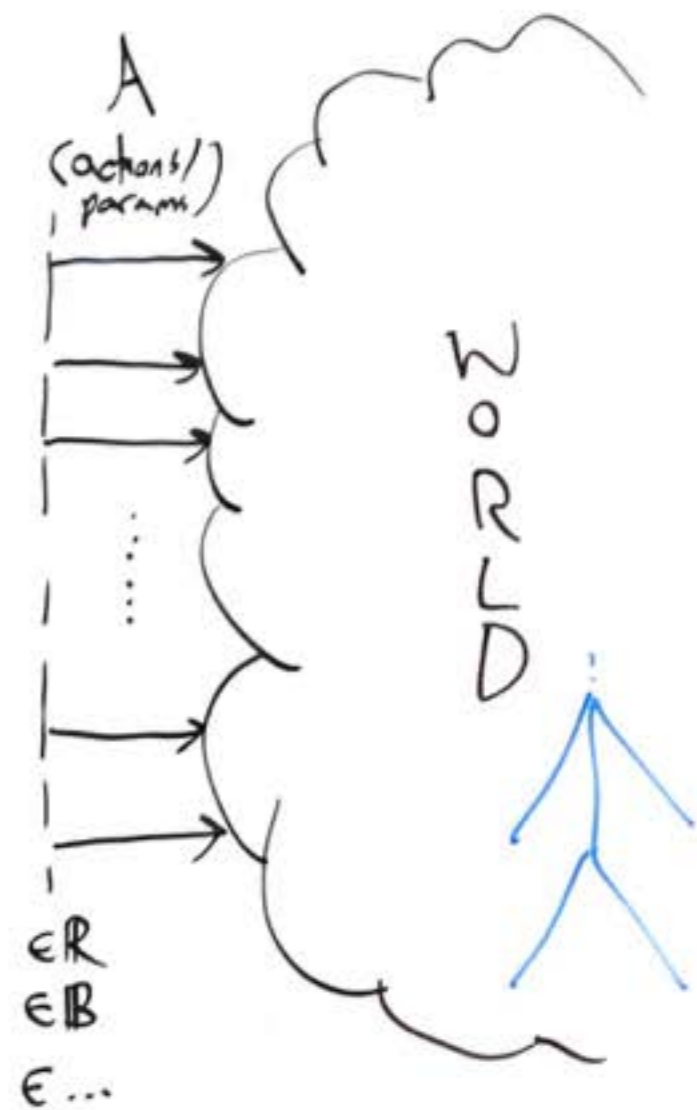
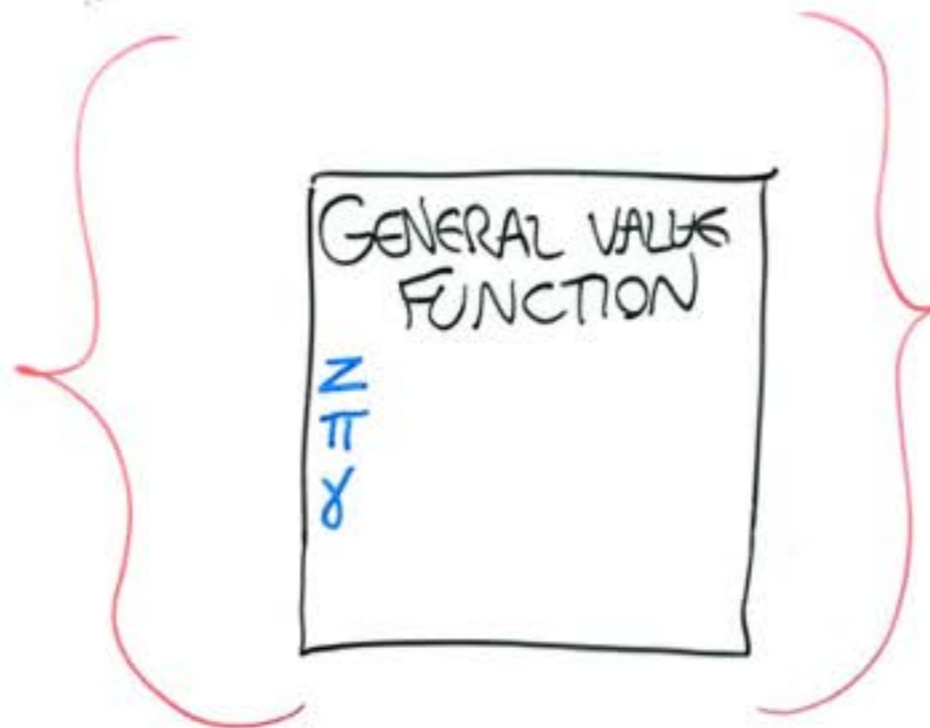

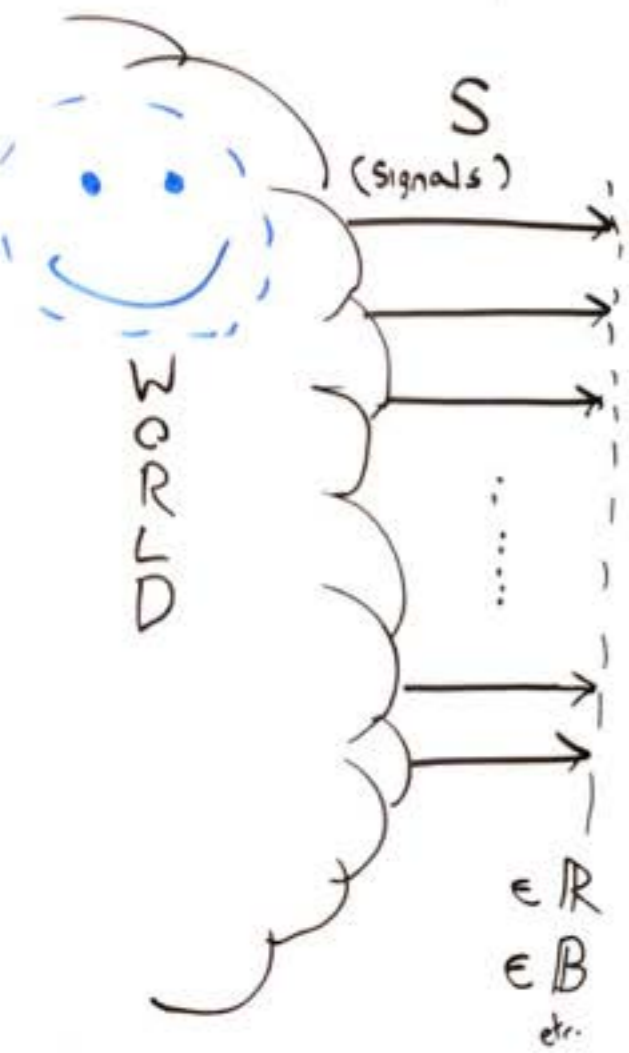

KNOWLEDGE

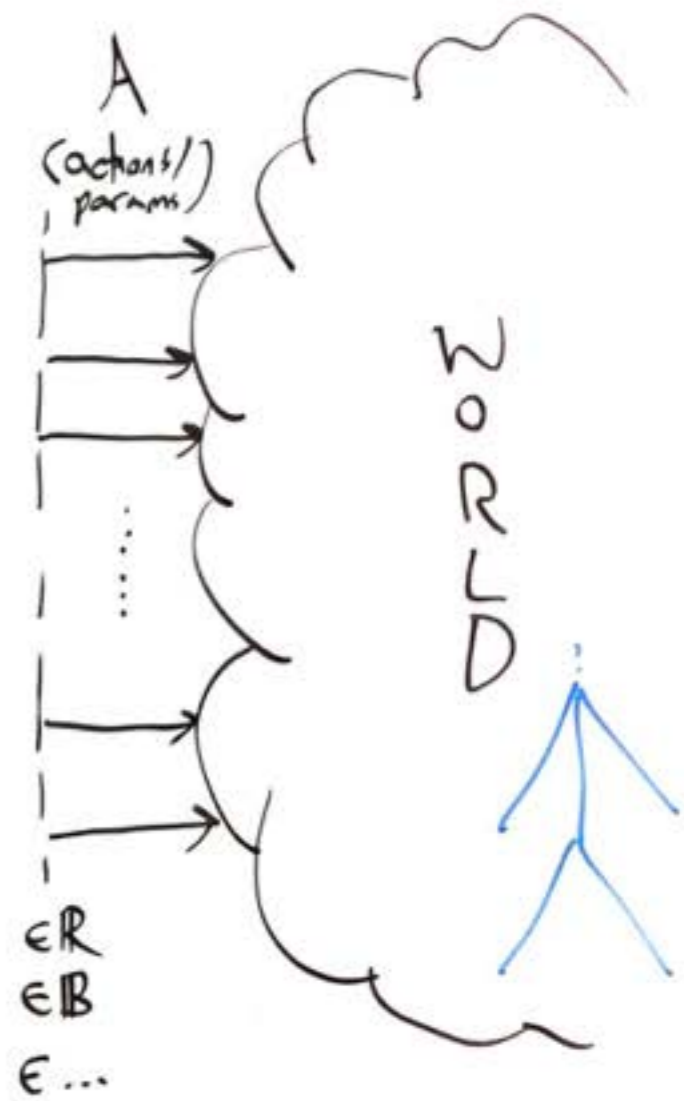
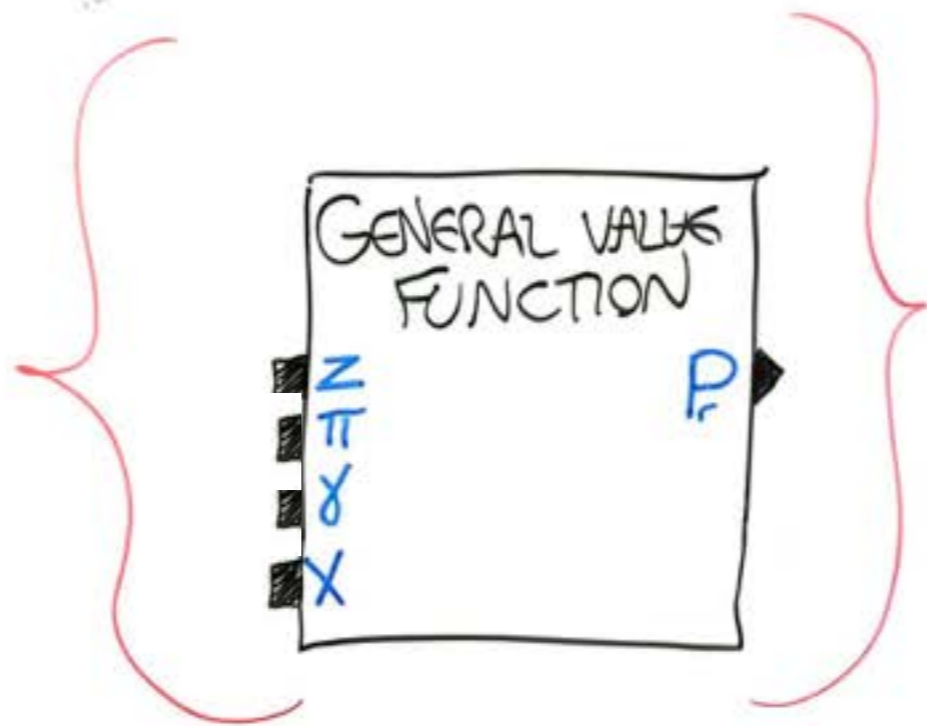

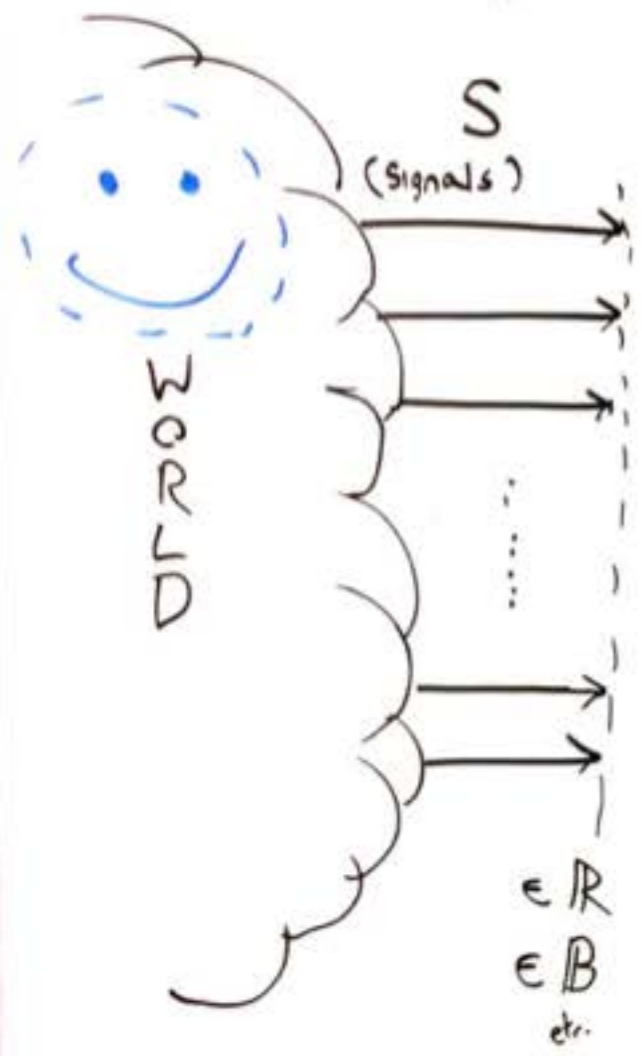

KNOWLEDGE

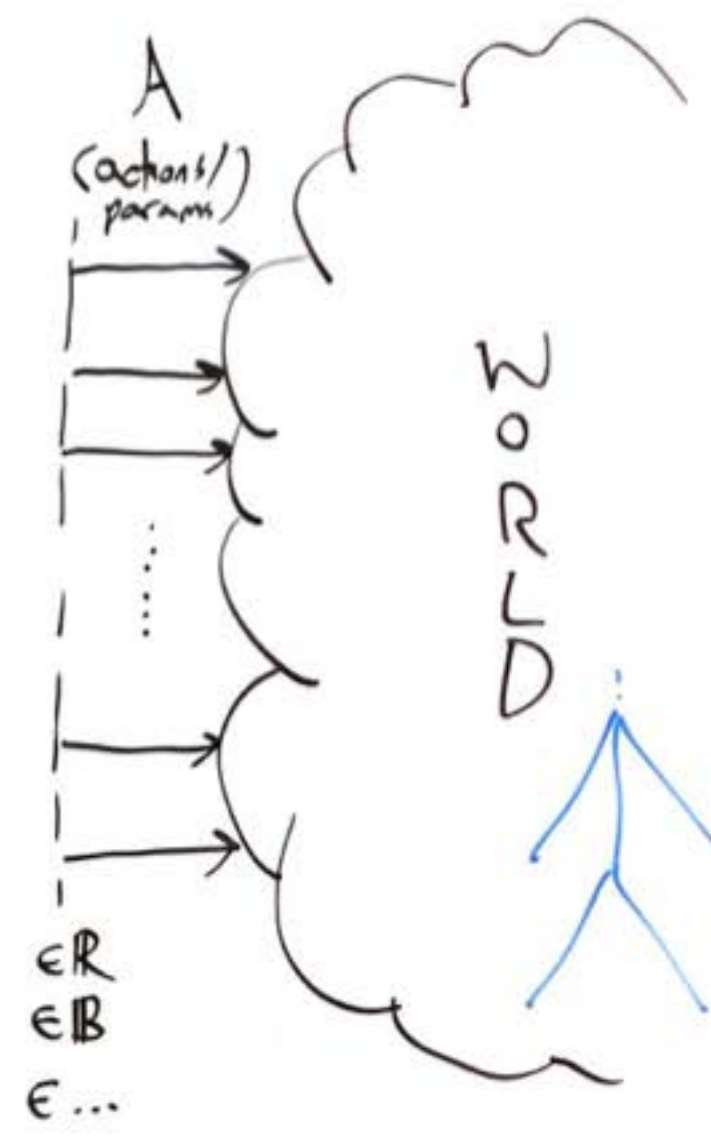
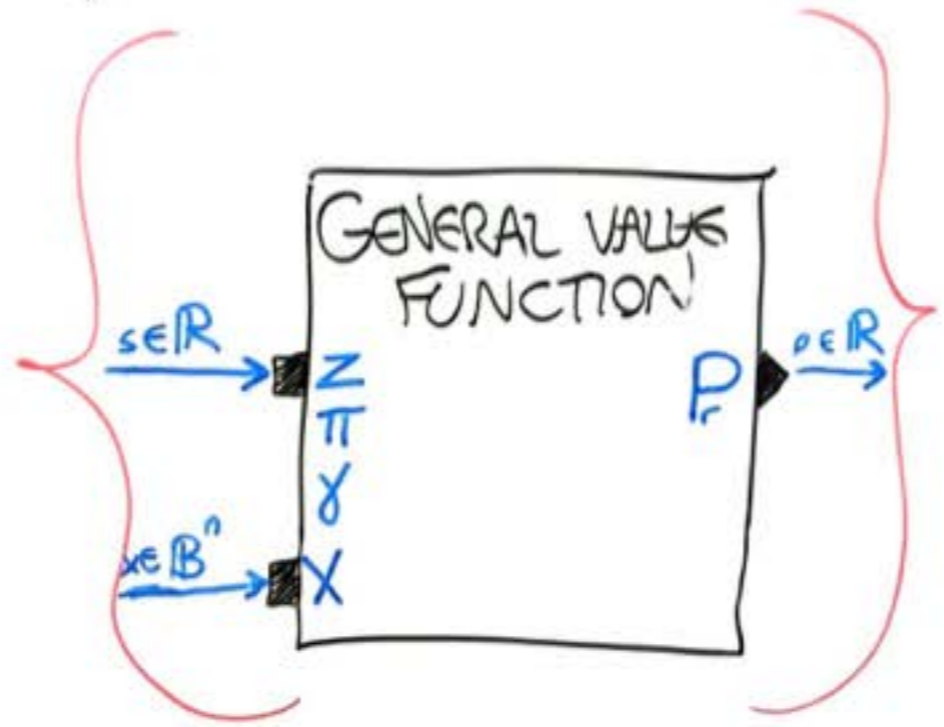

KNOWLEDGE

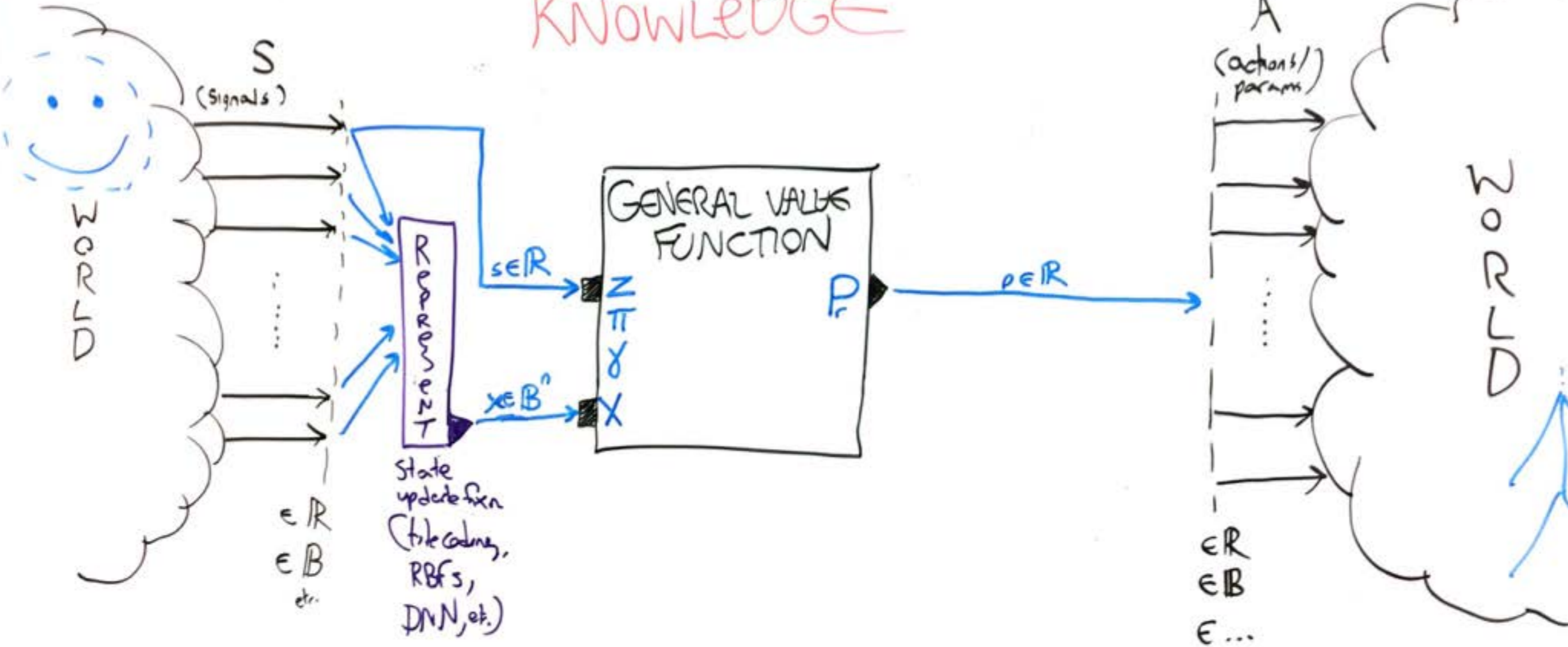

KNOWLEDGE

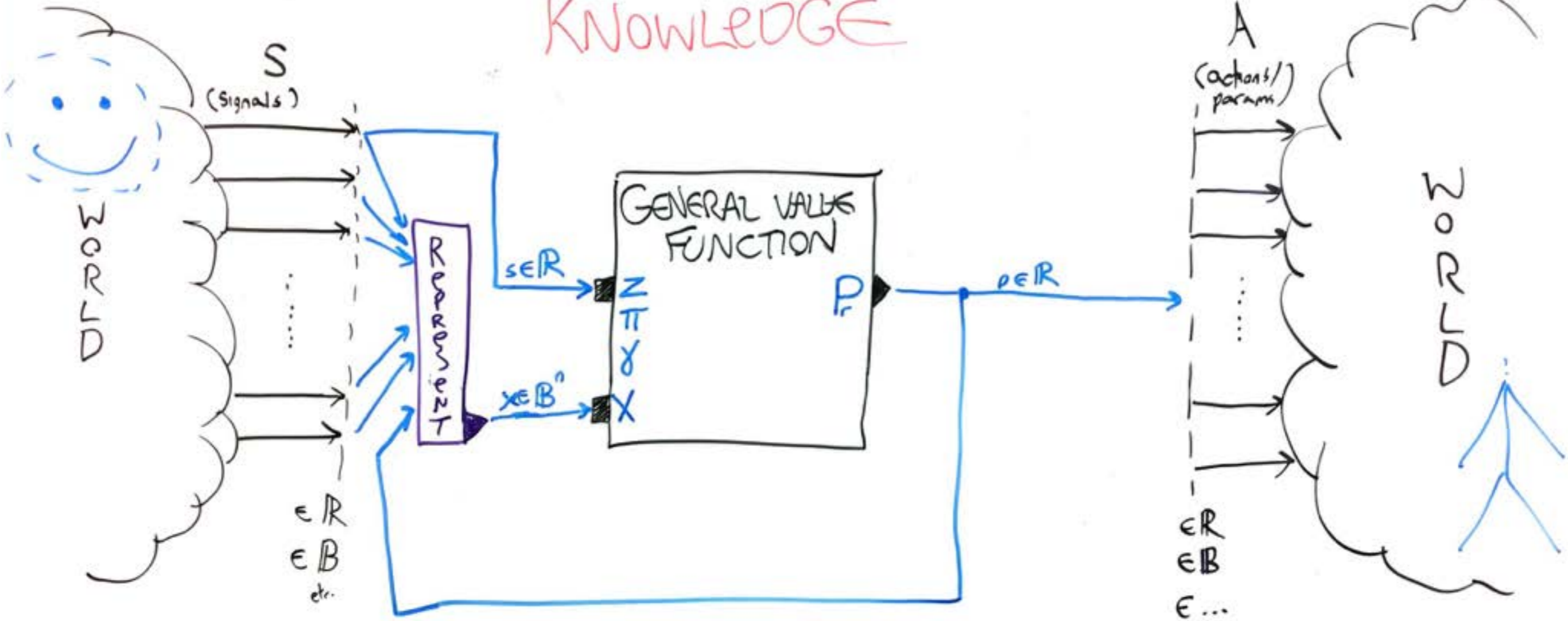

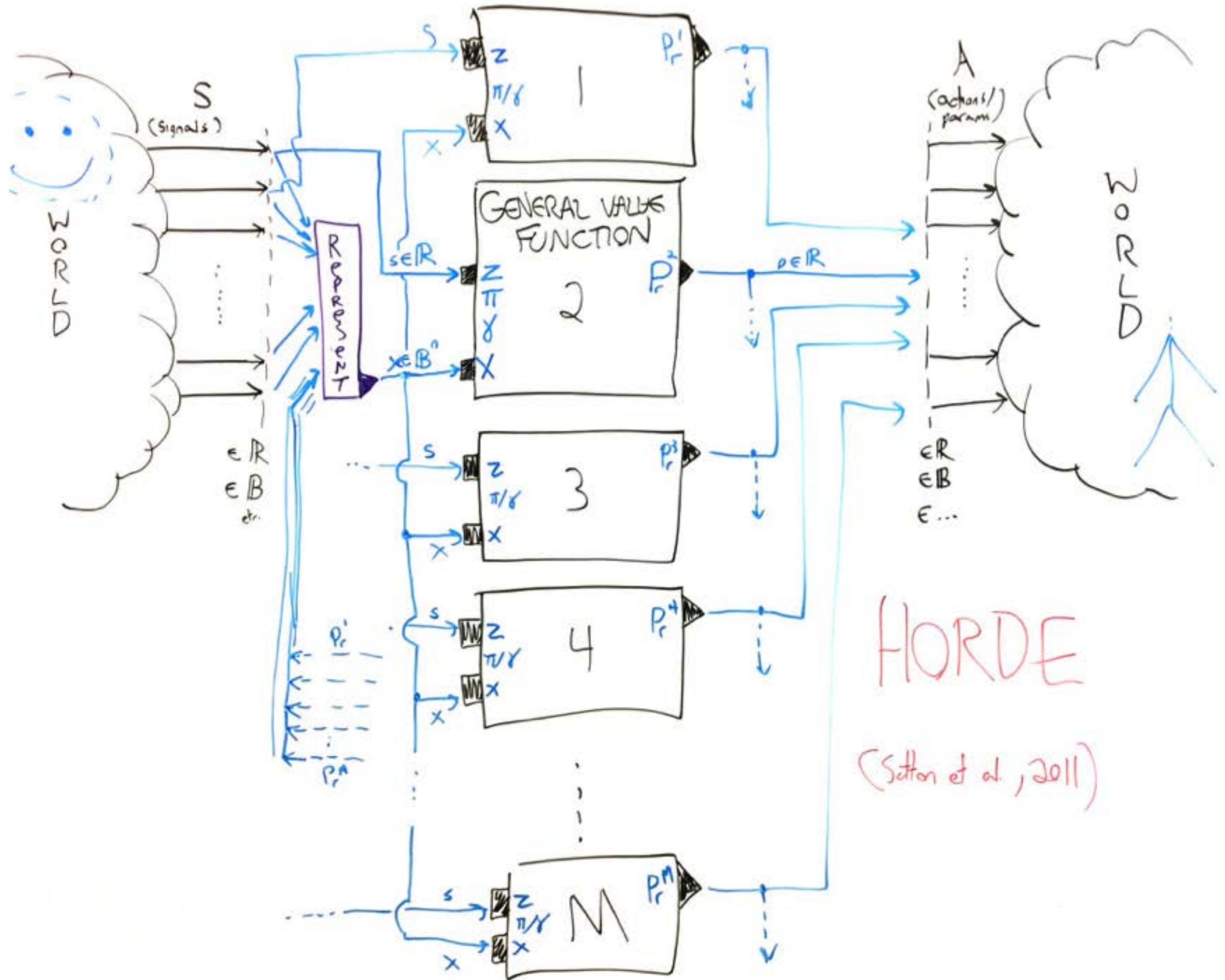

HORDE
 (Sutton et al., 2011)

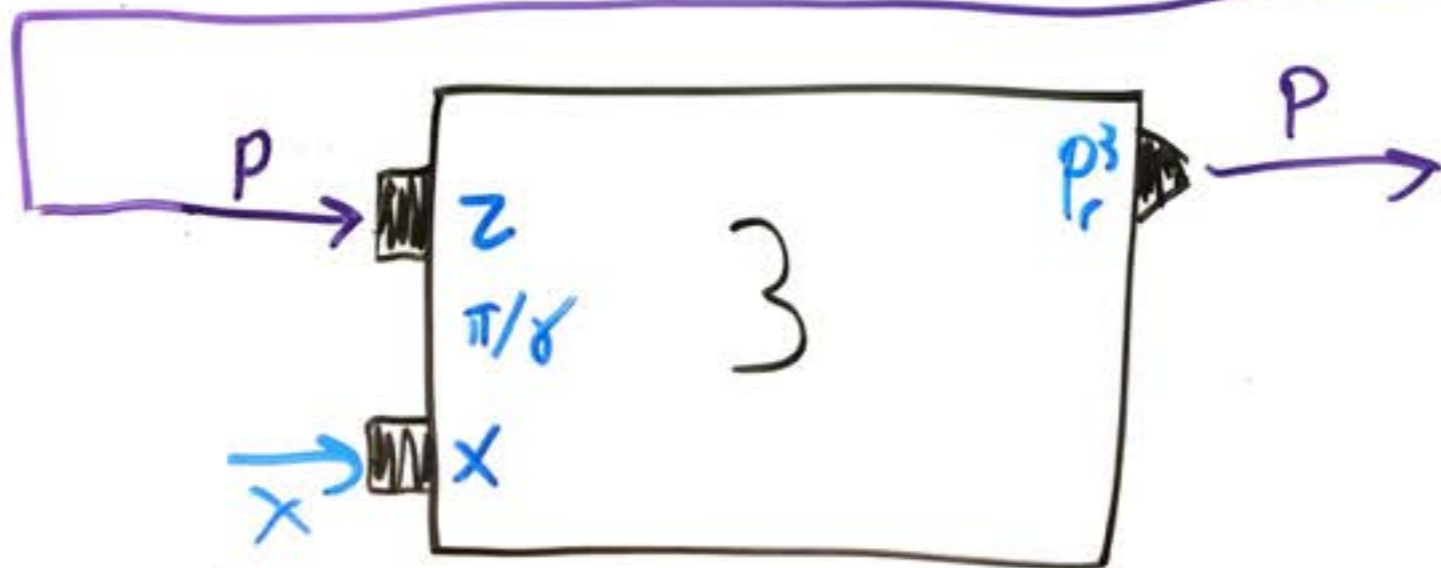
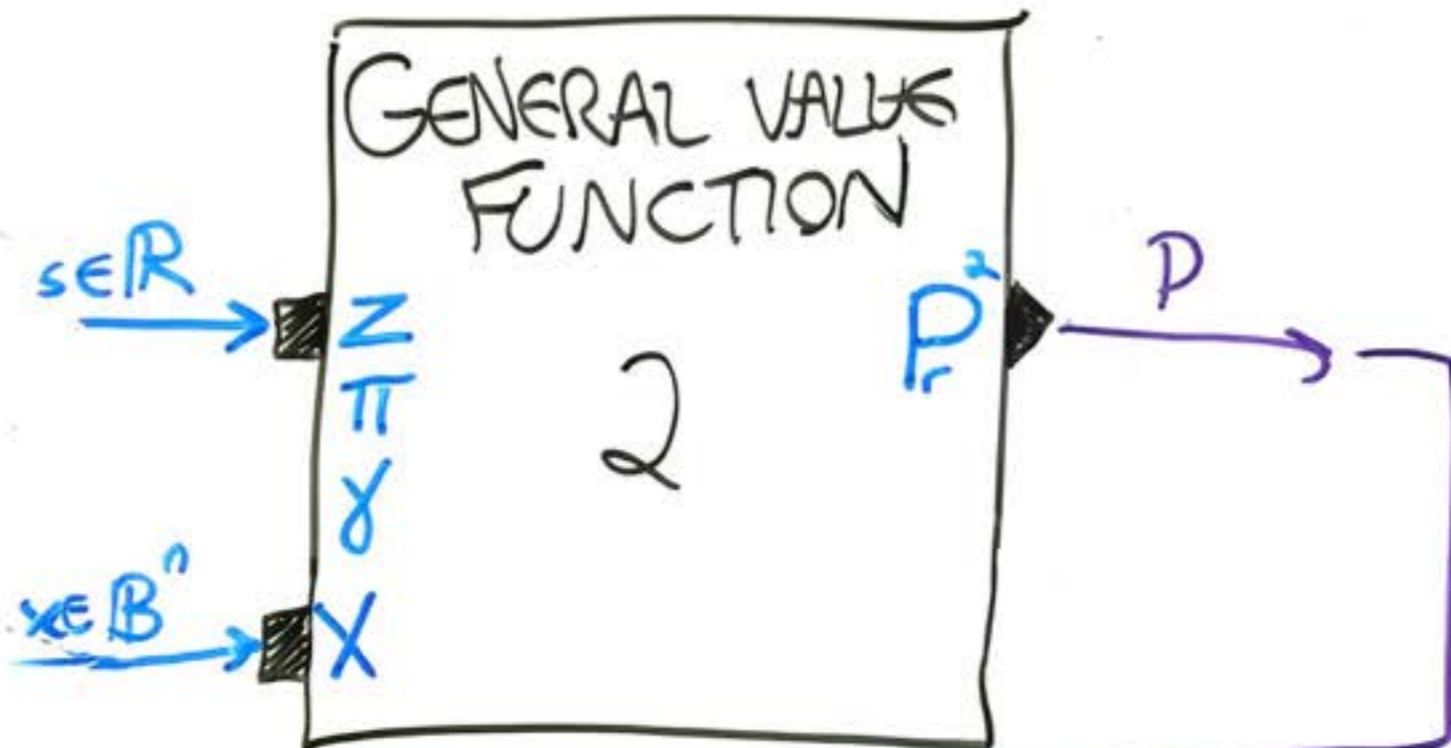
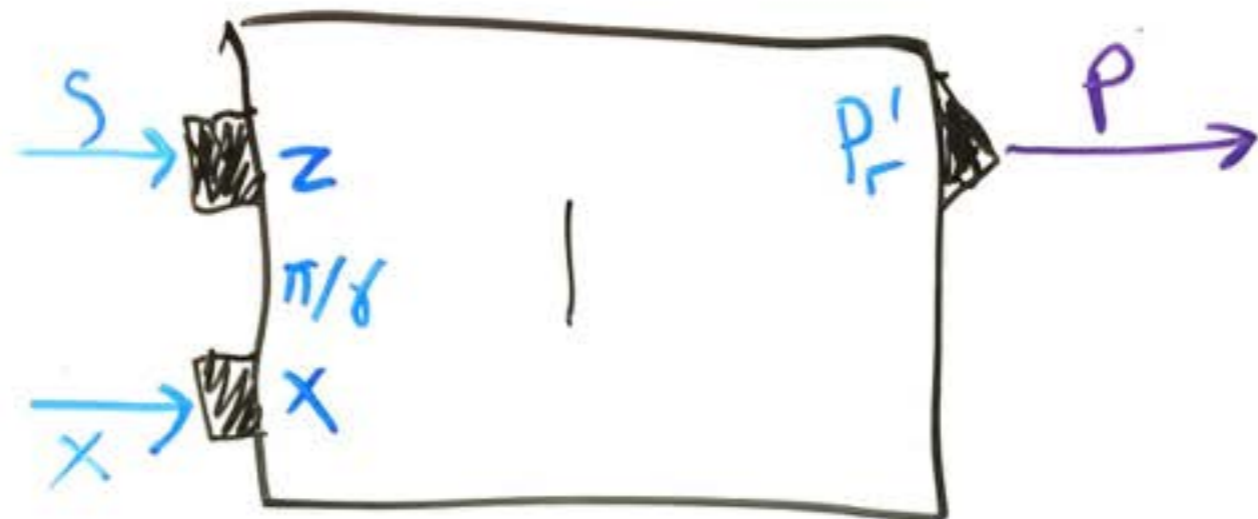

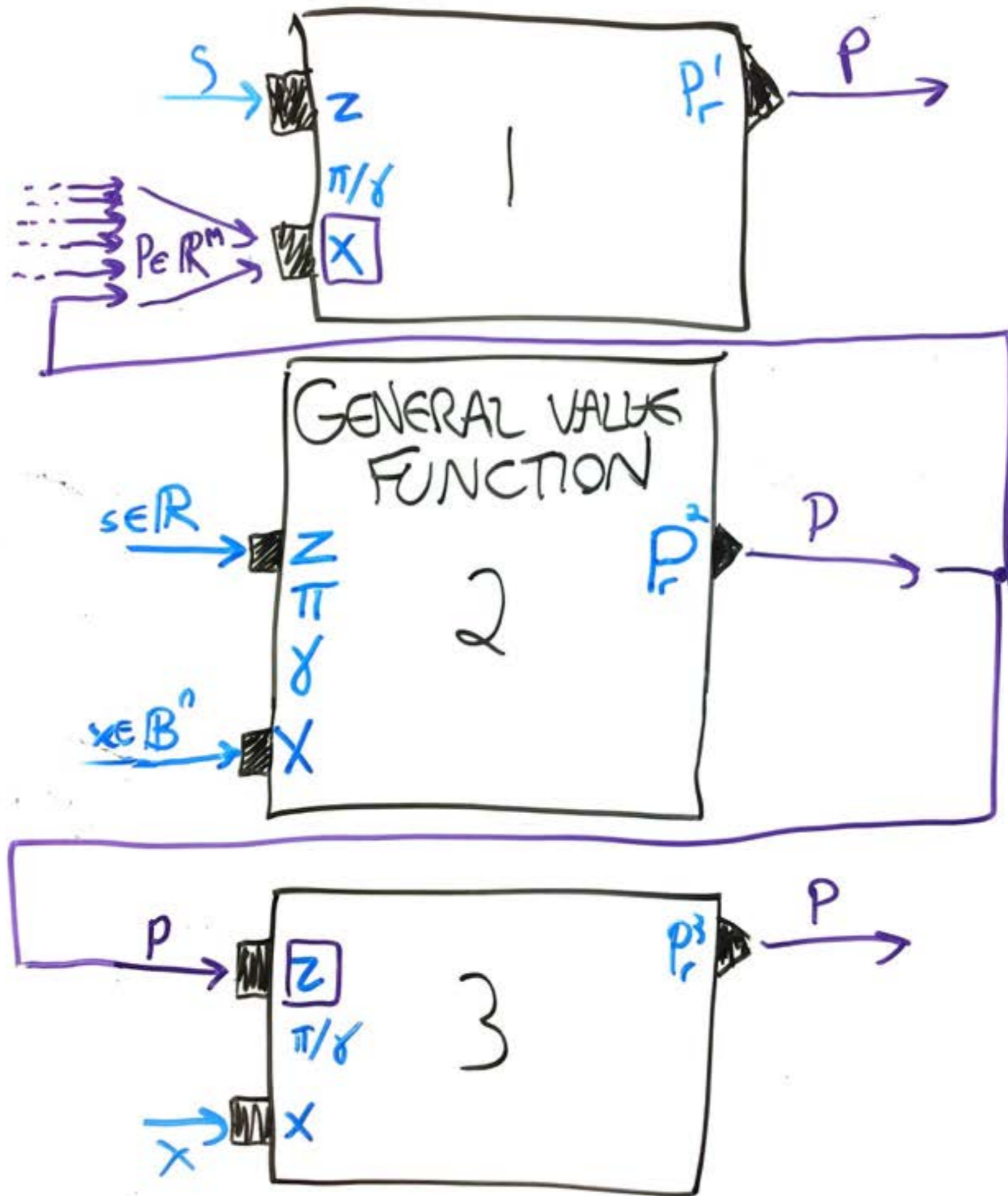

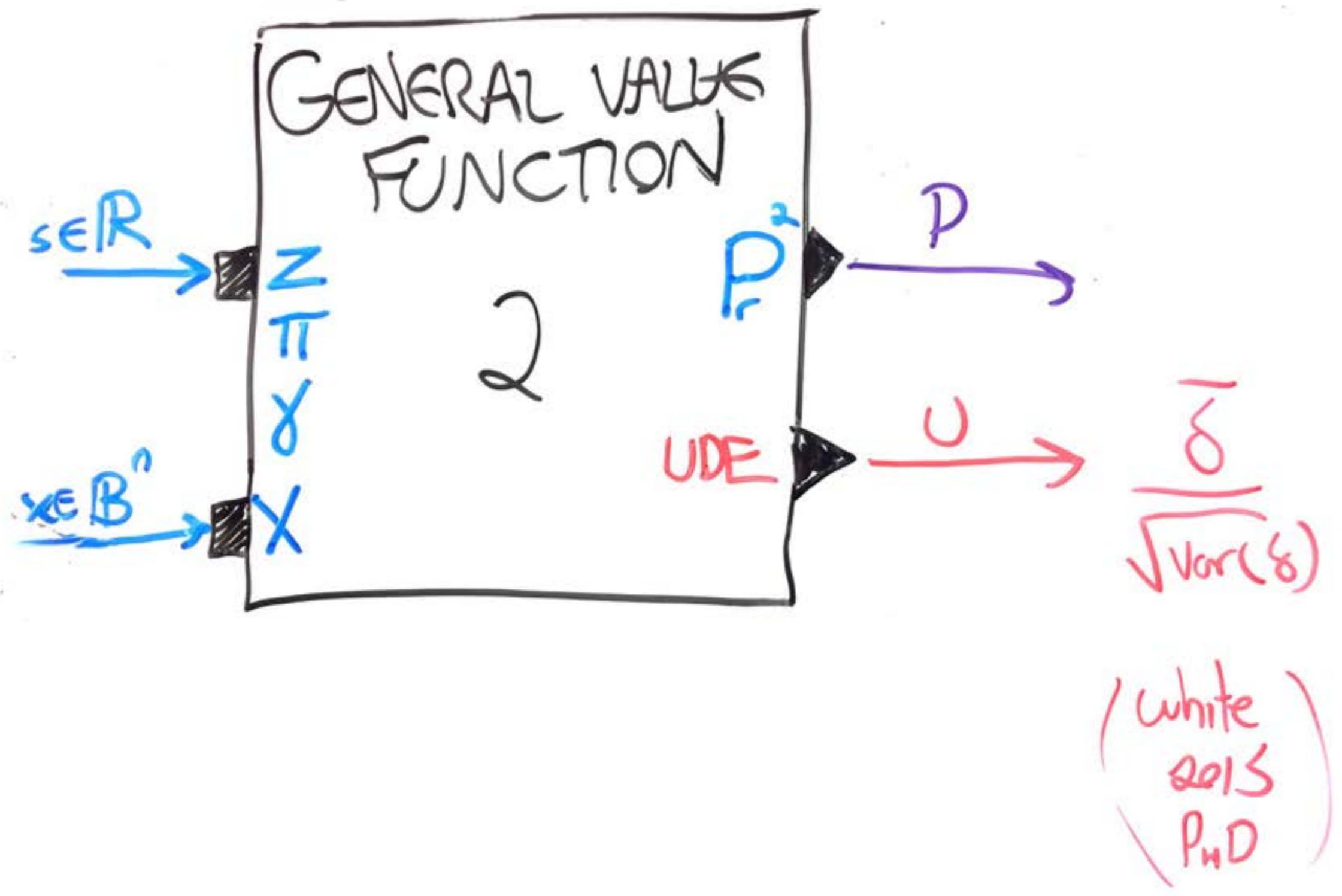

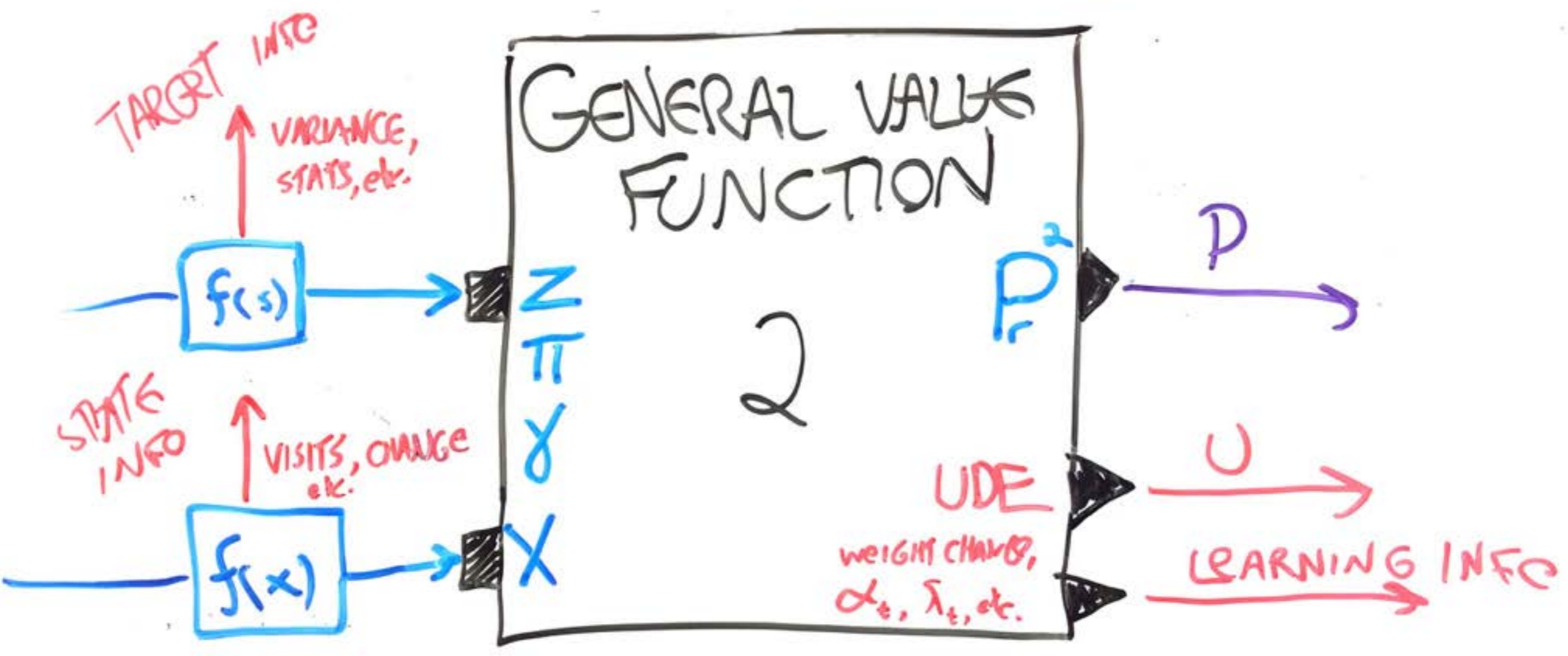

Sherstan et al.
2016, AGI

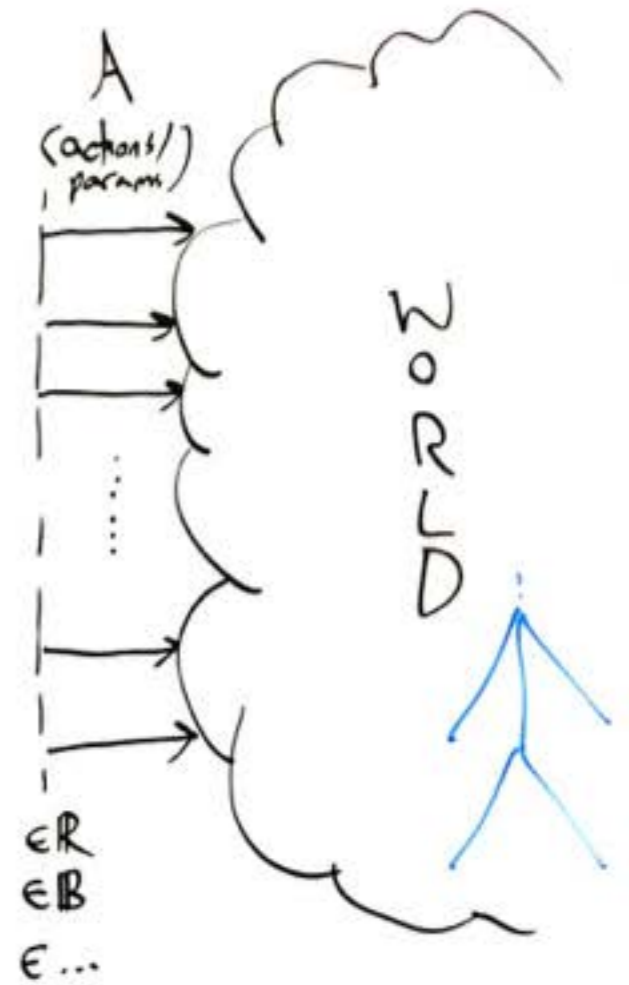
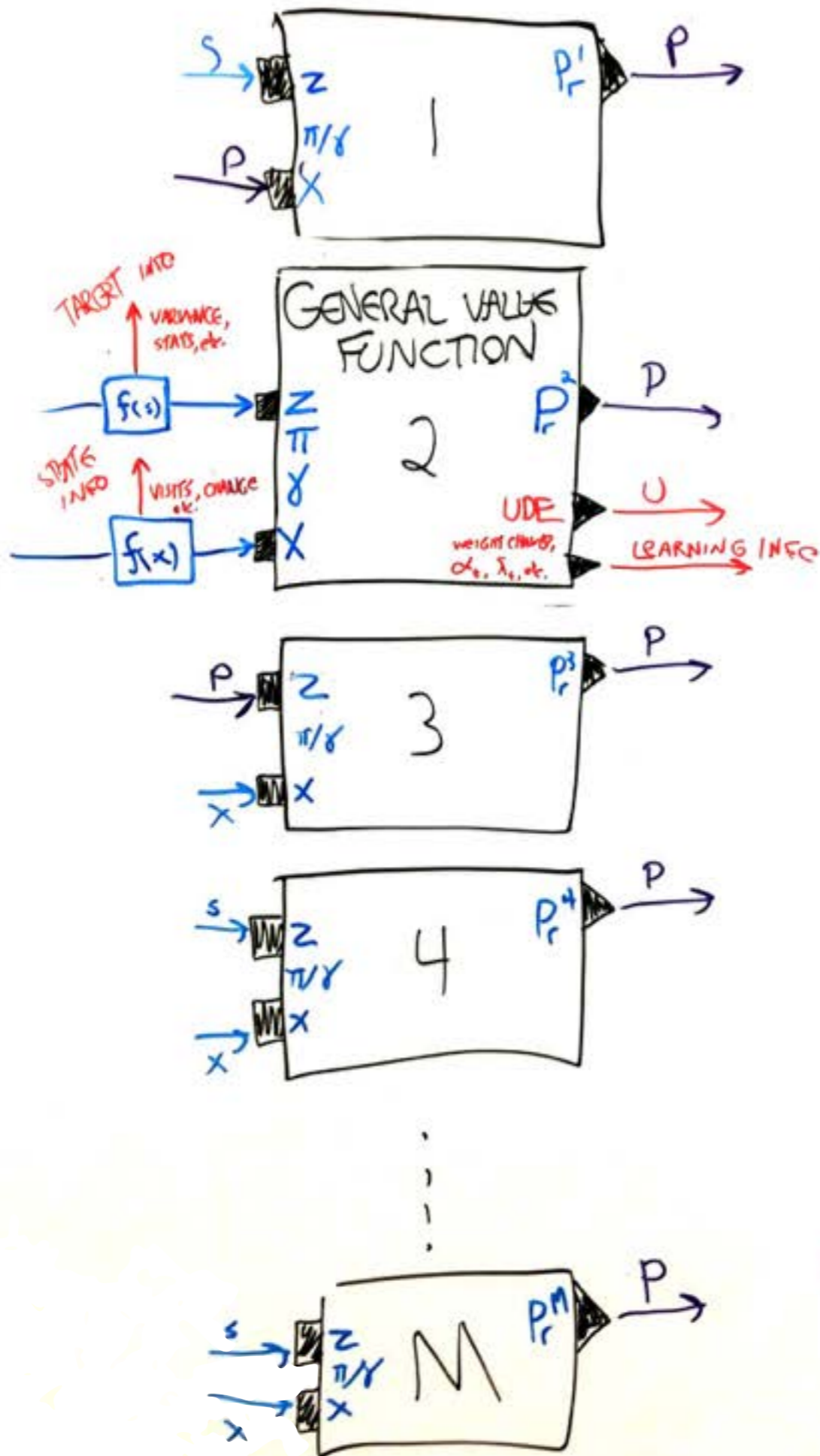
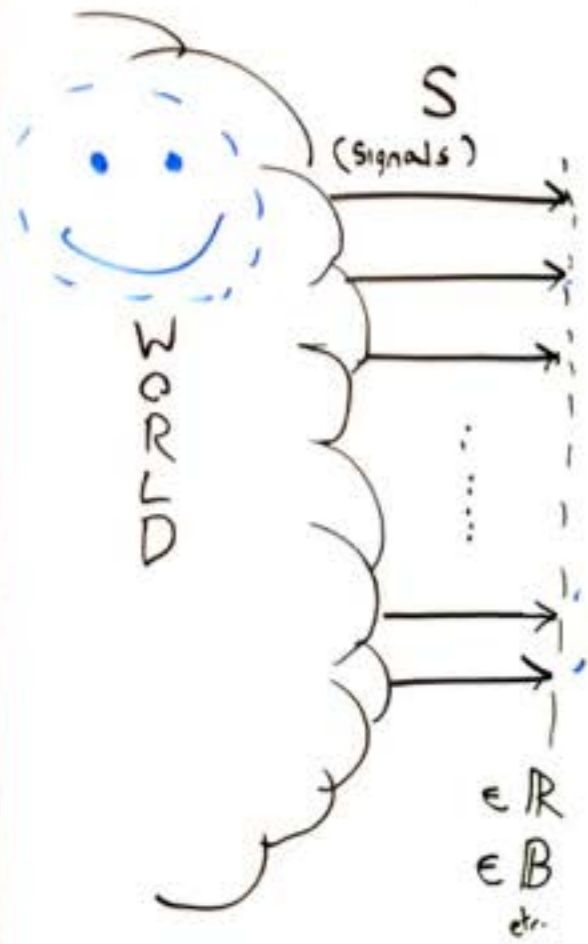

GVFs as
Generators
 of
 Sensorimotor
 data!

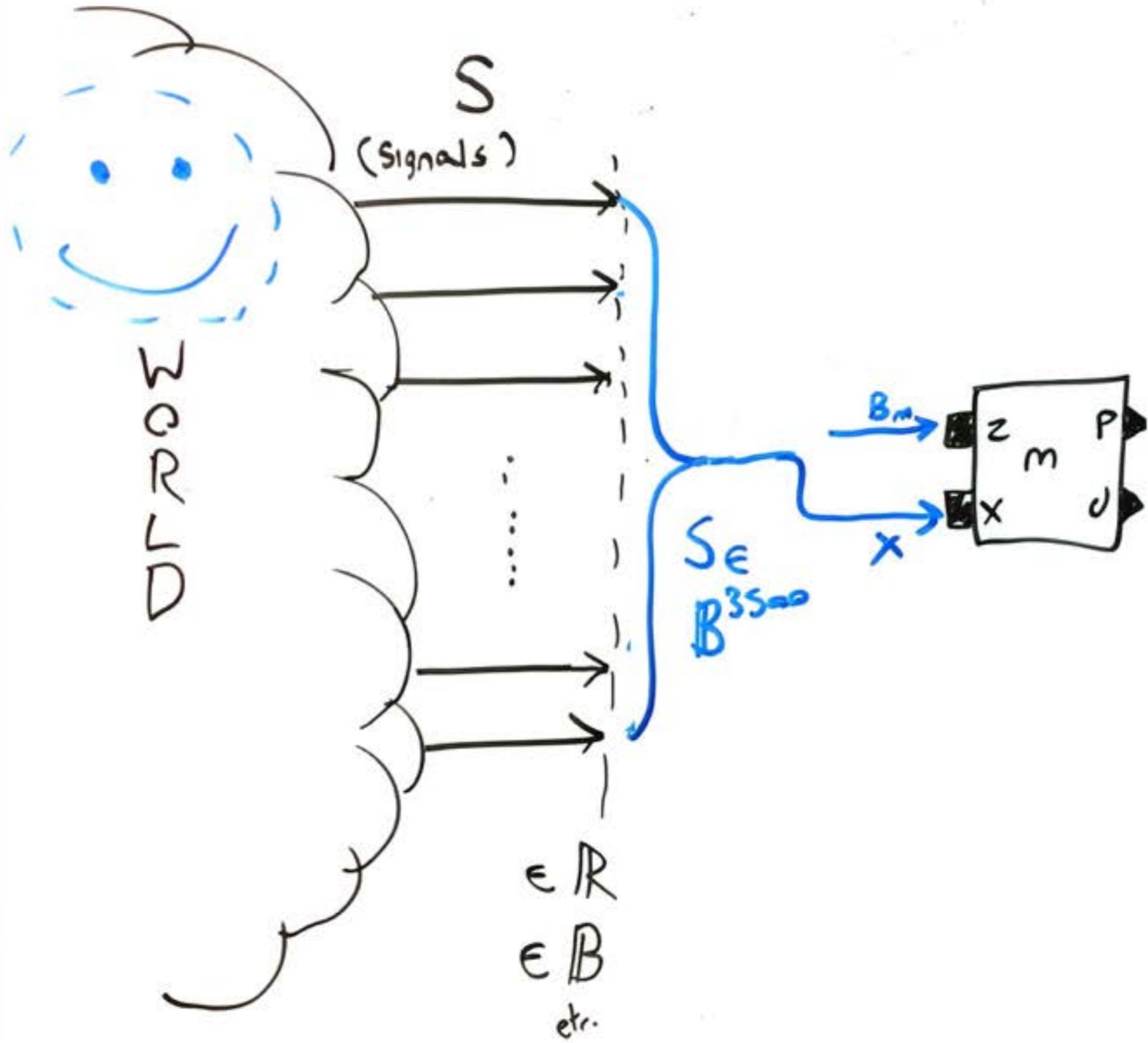



$S \in \mathbb{B}^{35 \times 30}$

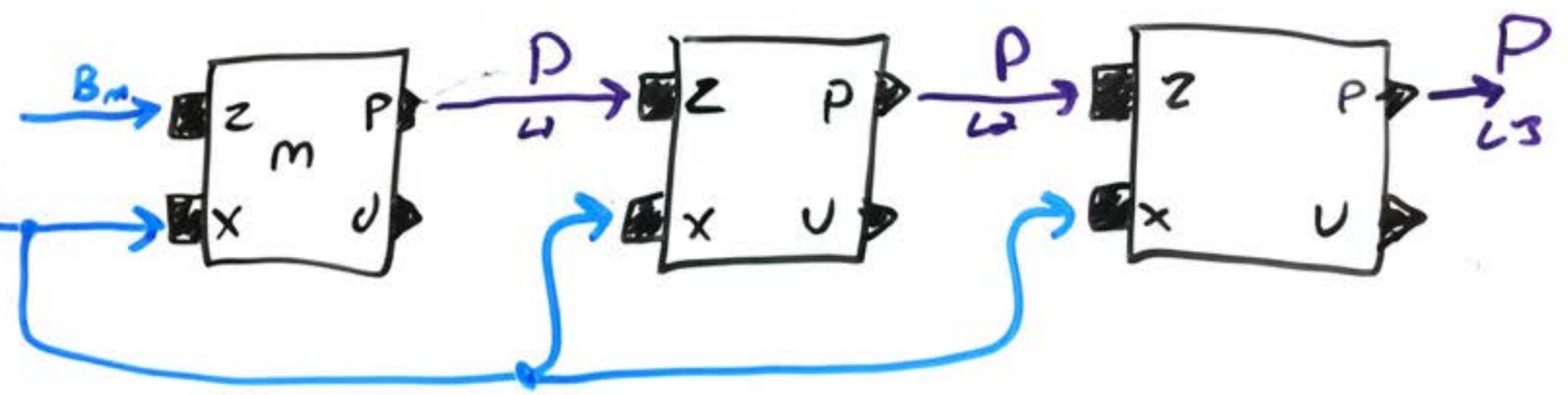

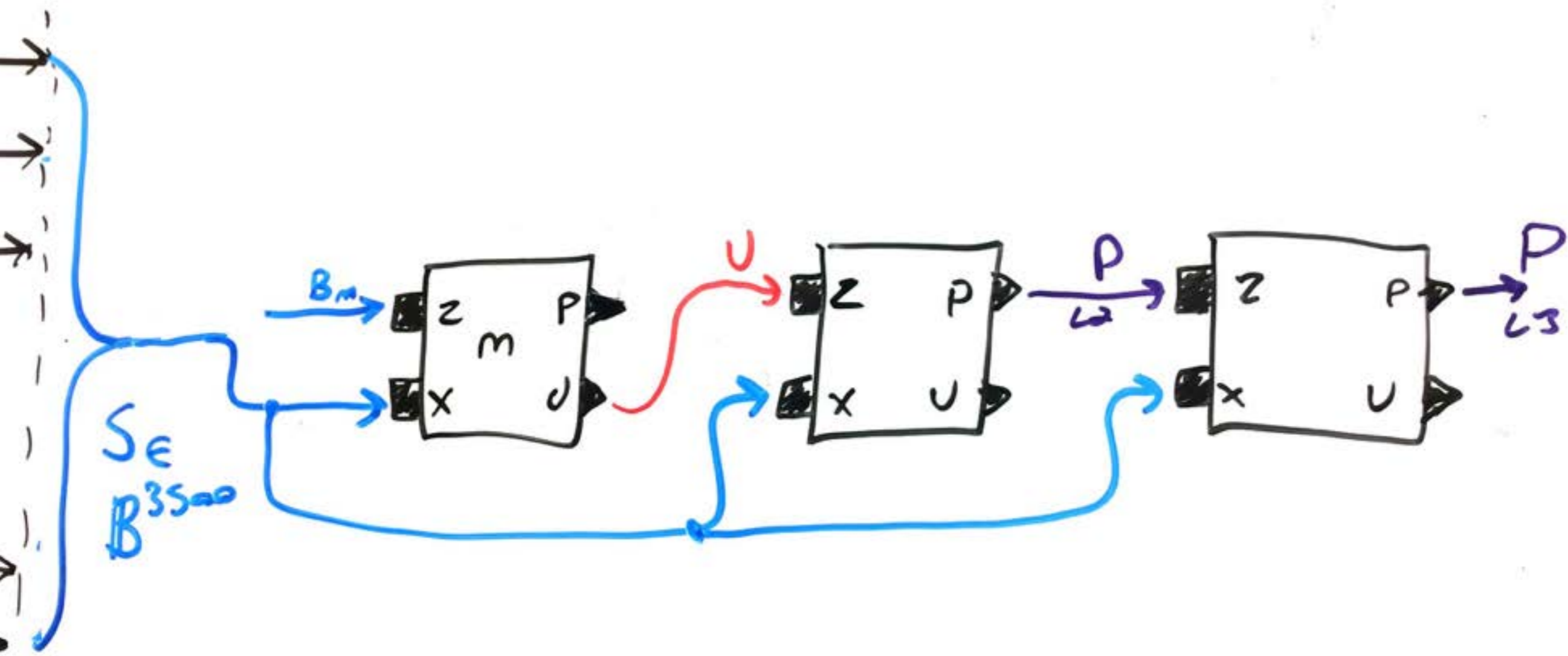

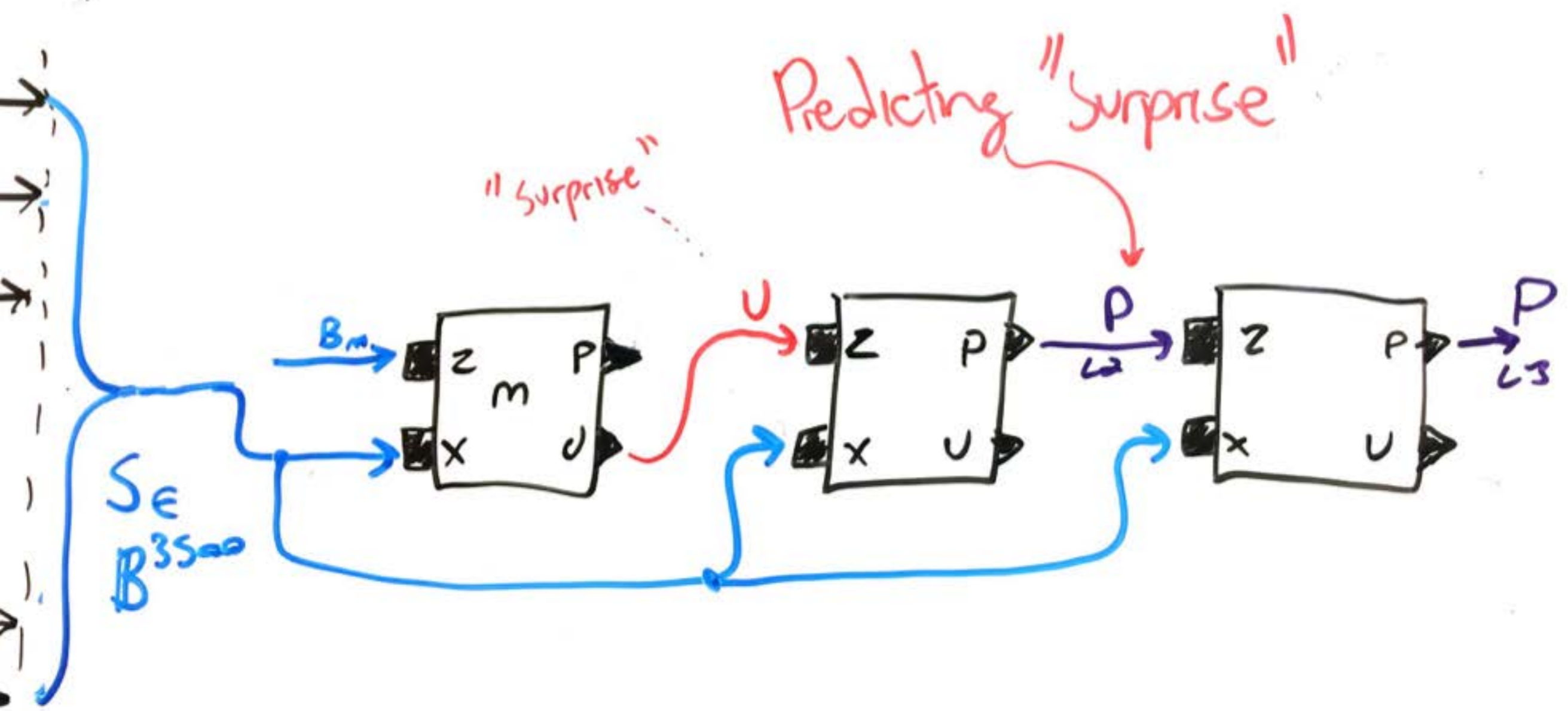

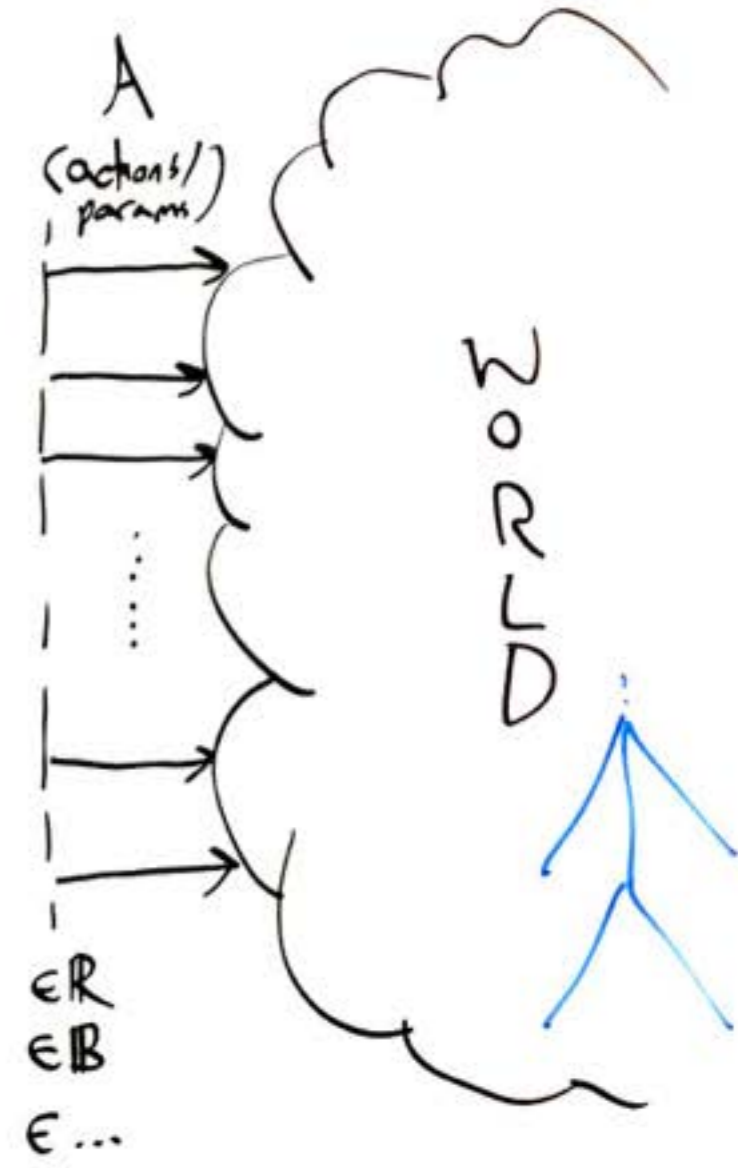
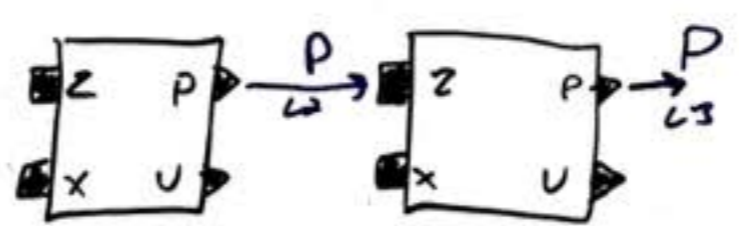
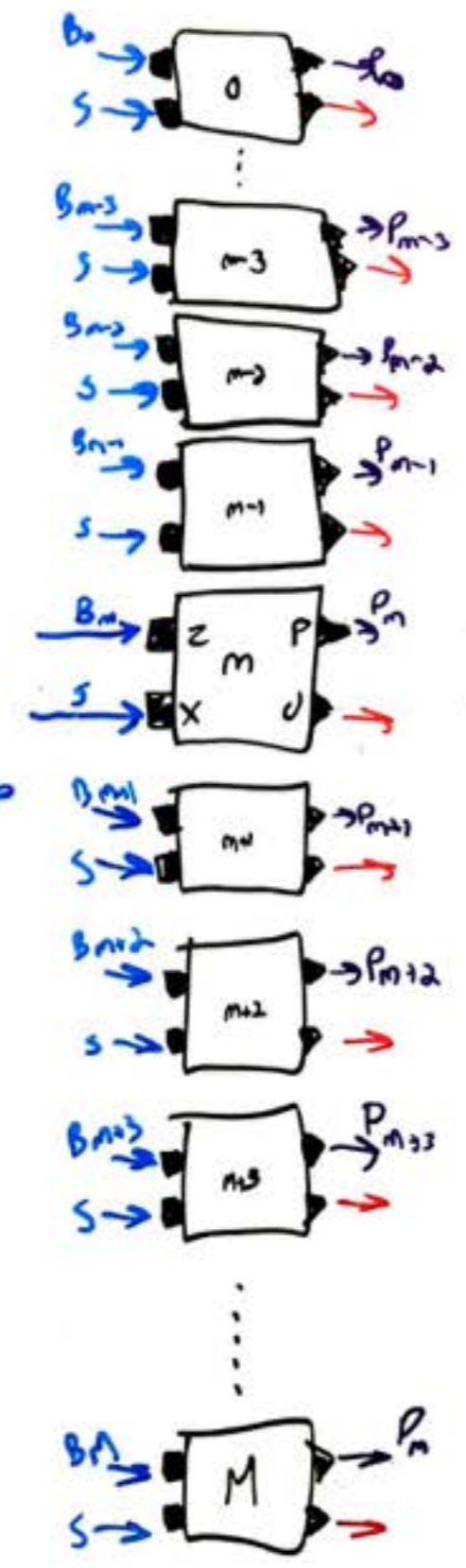
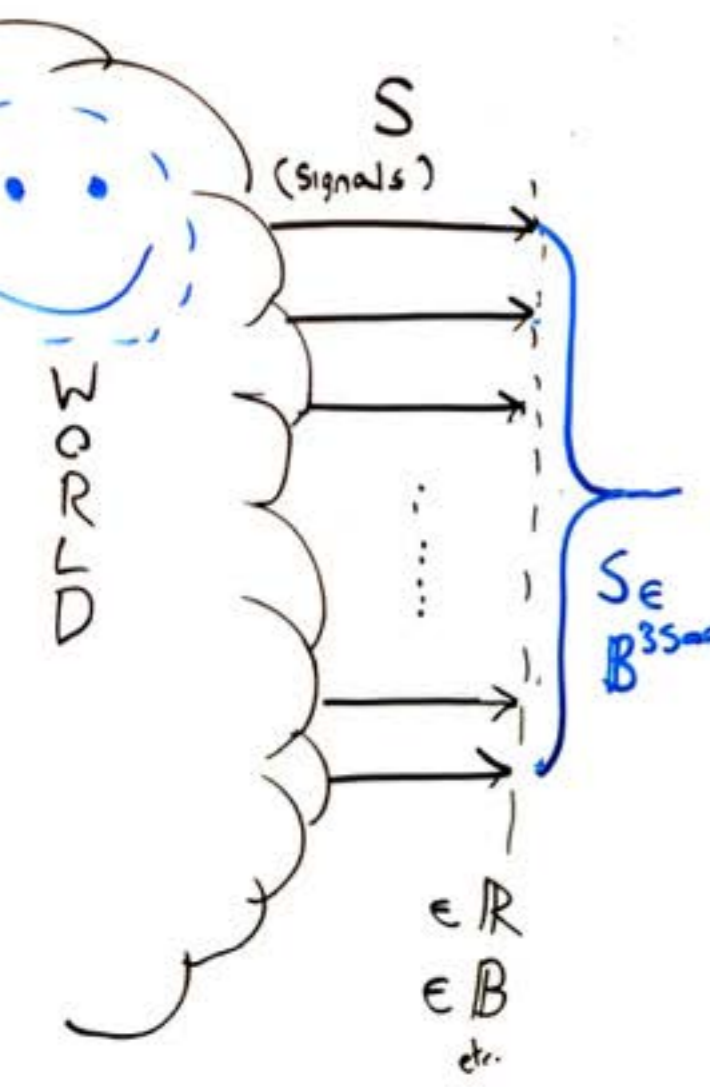

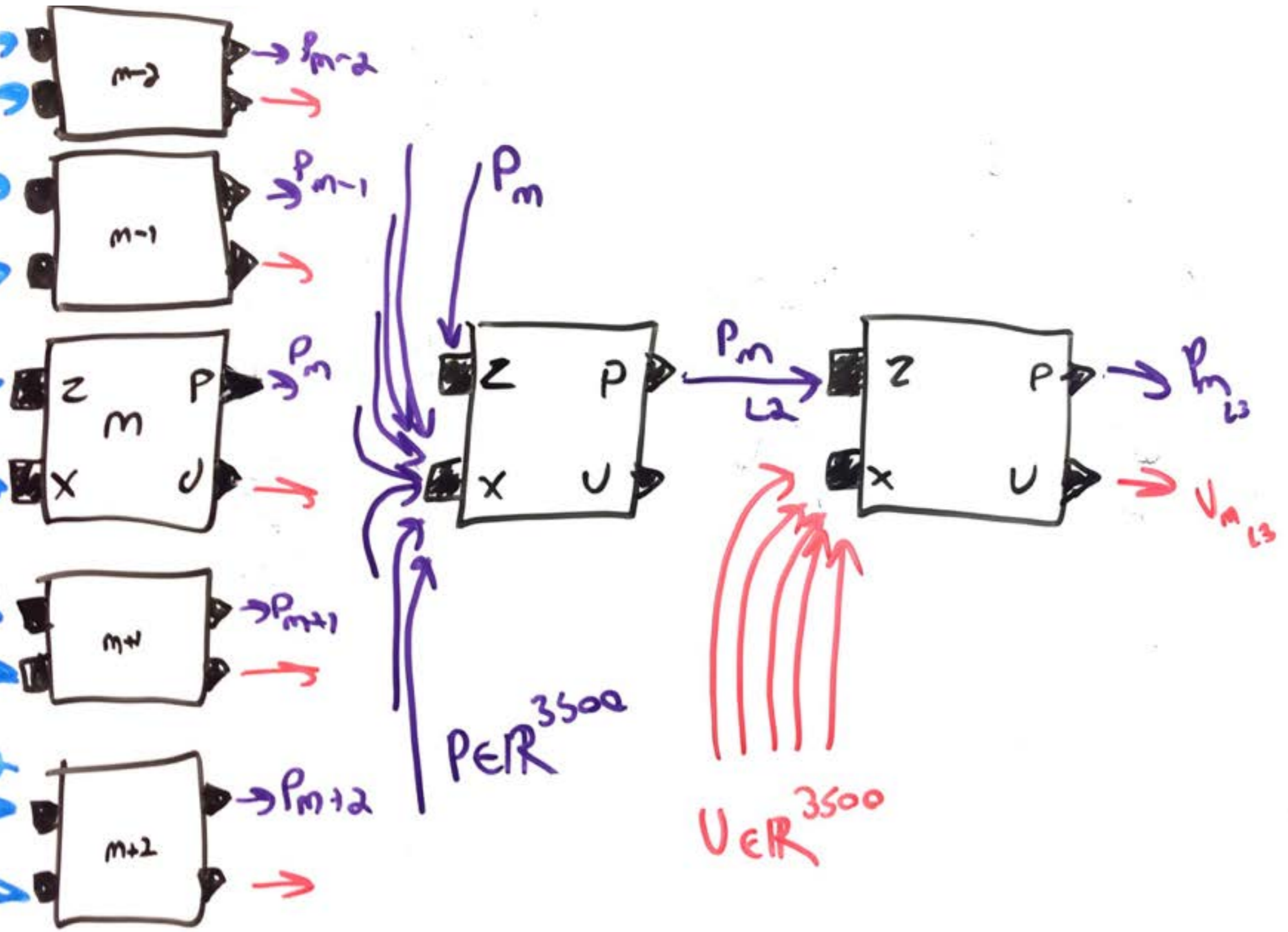

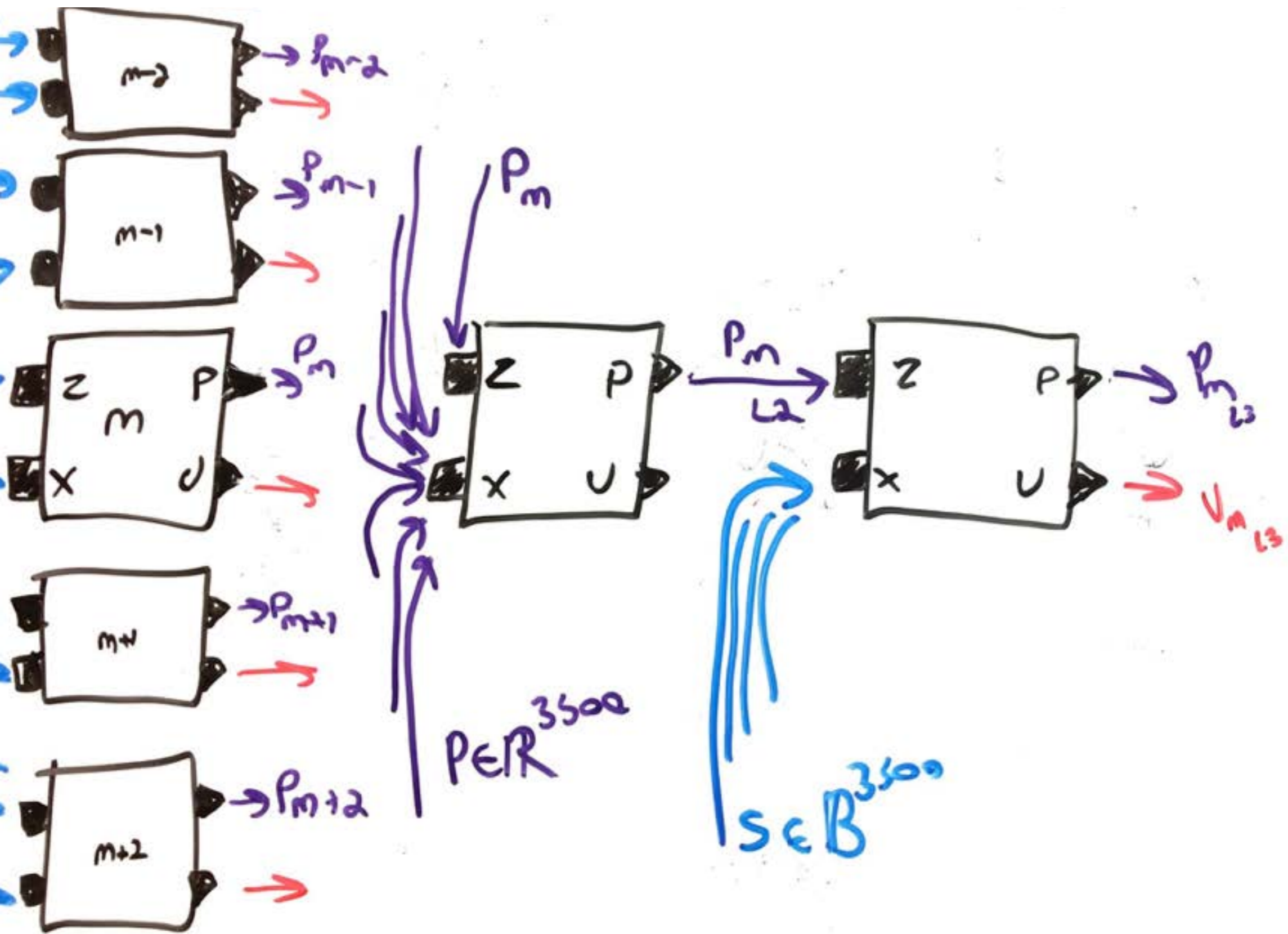

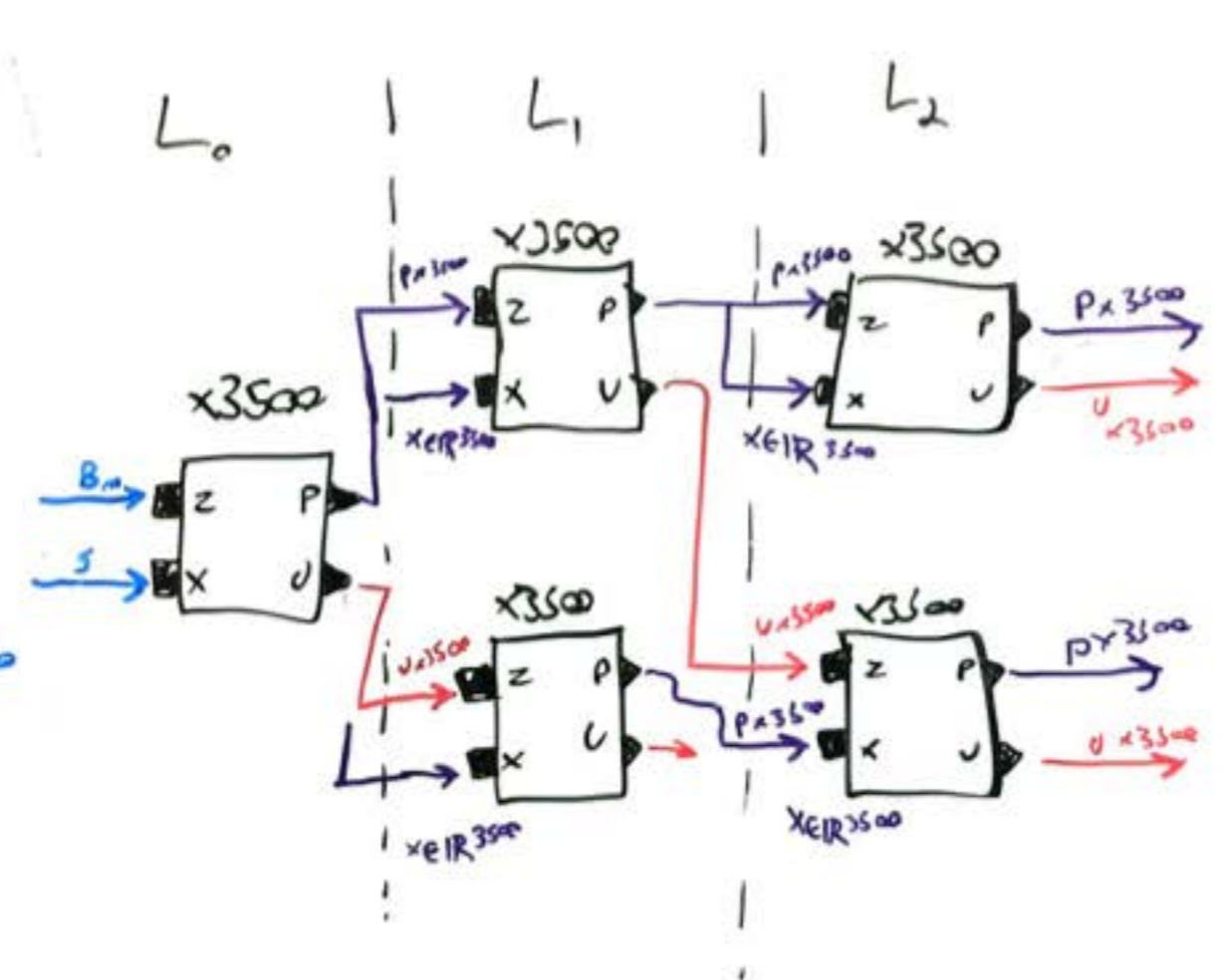
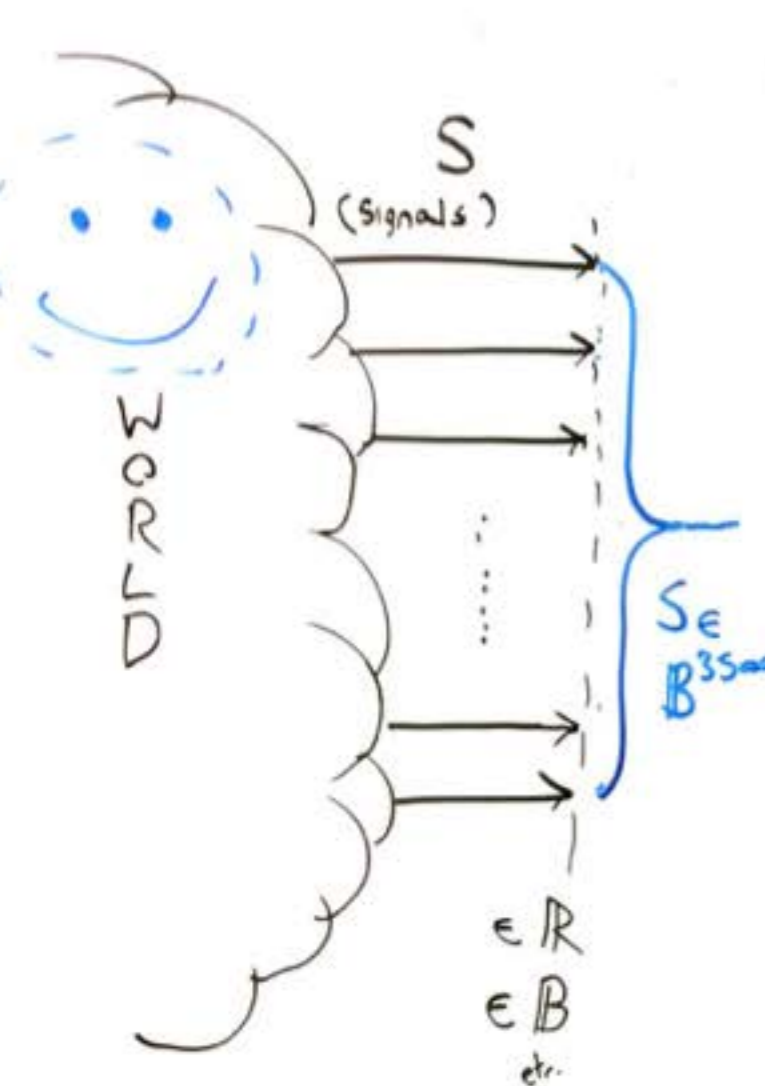

(PILARSKI & SHERSTAN, BioRob 2016)

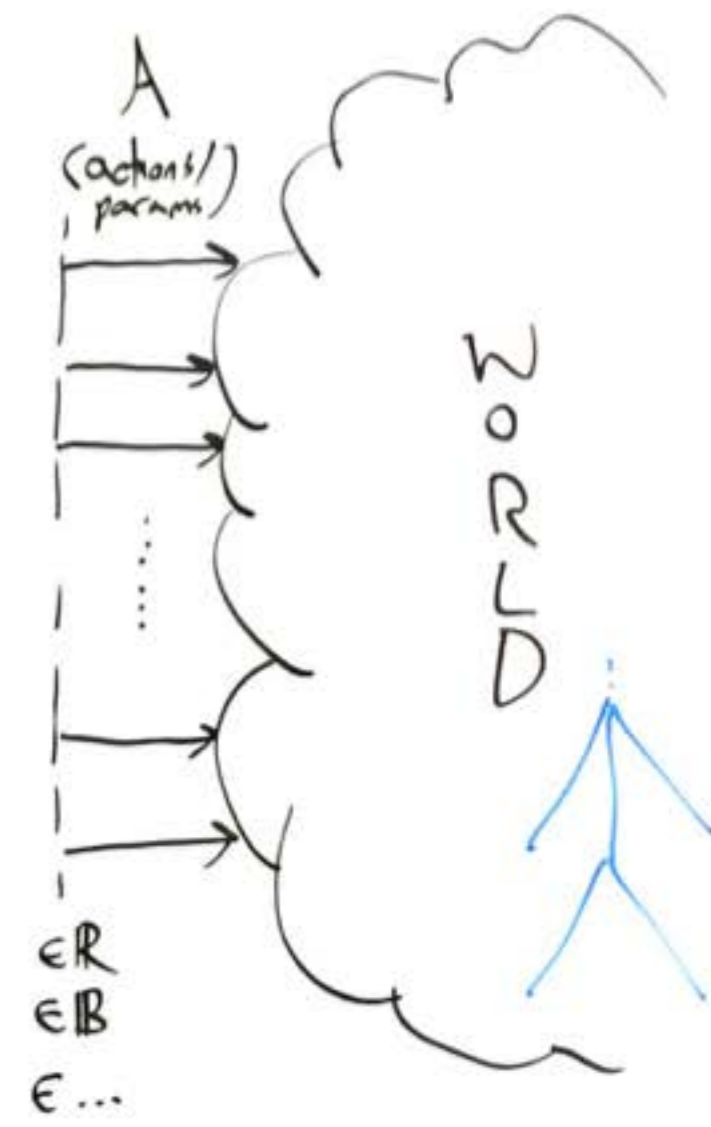

L_0

L_1

L_2

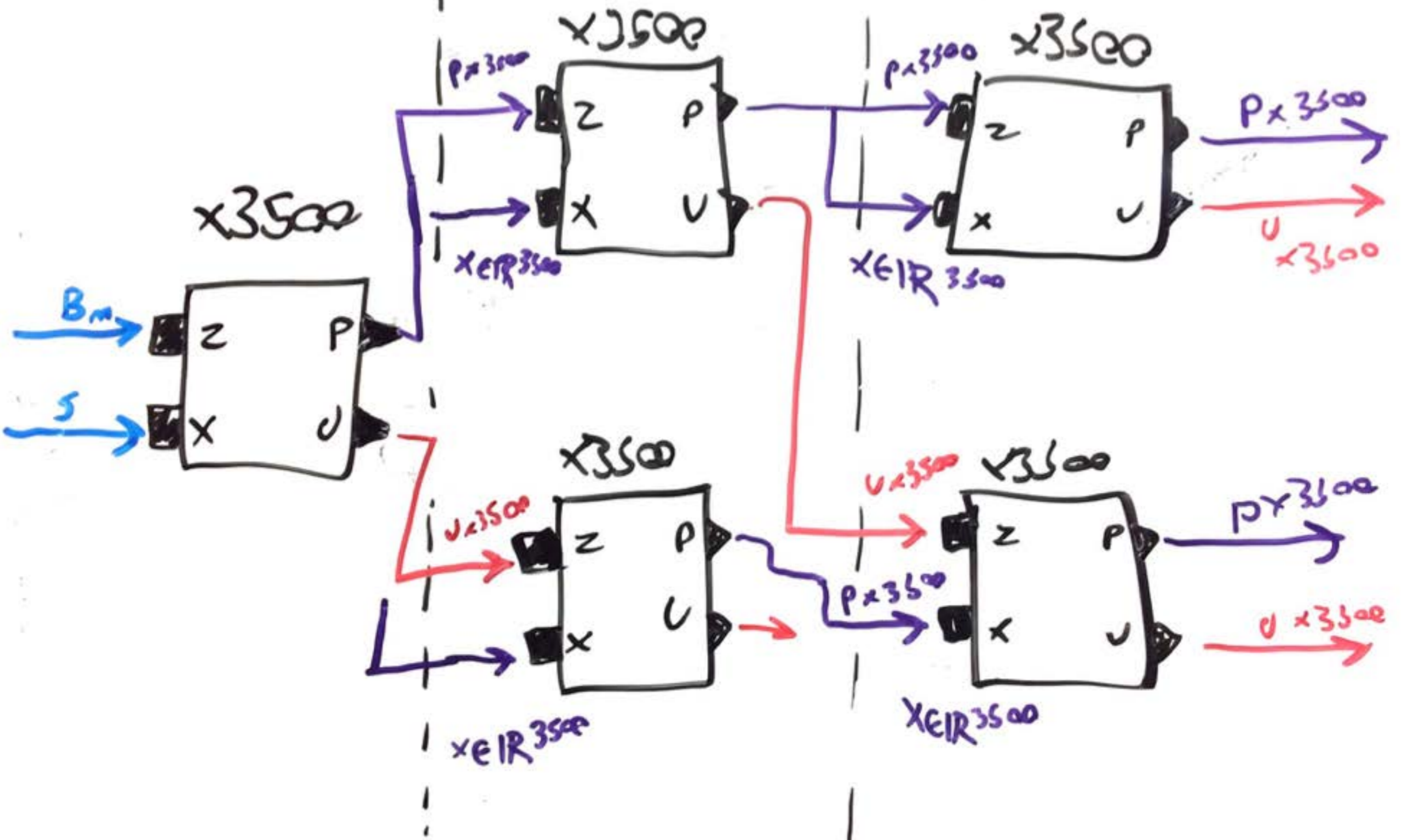

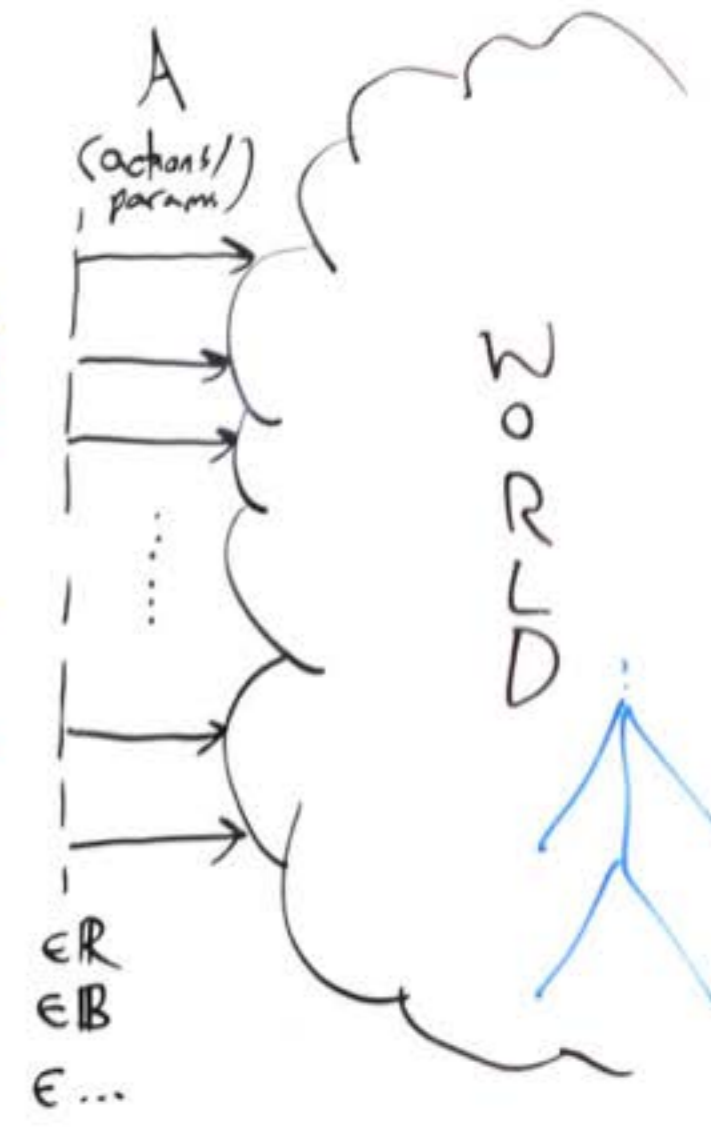
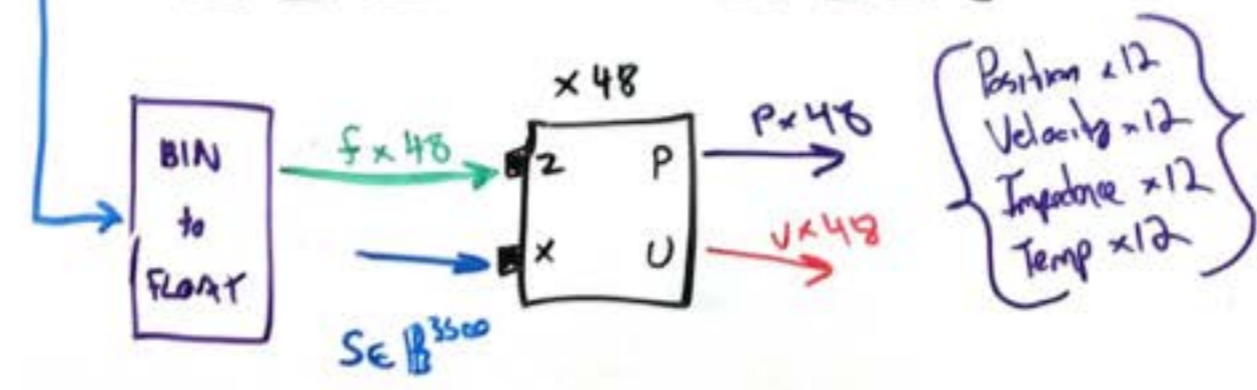
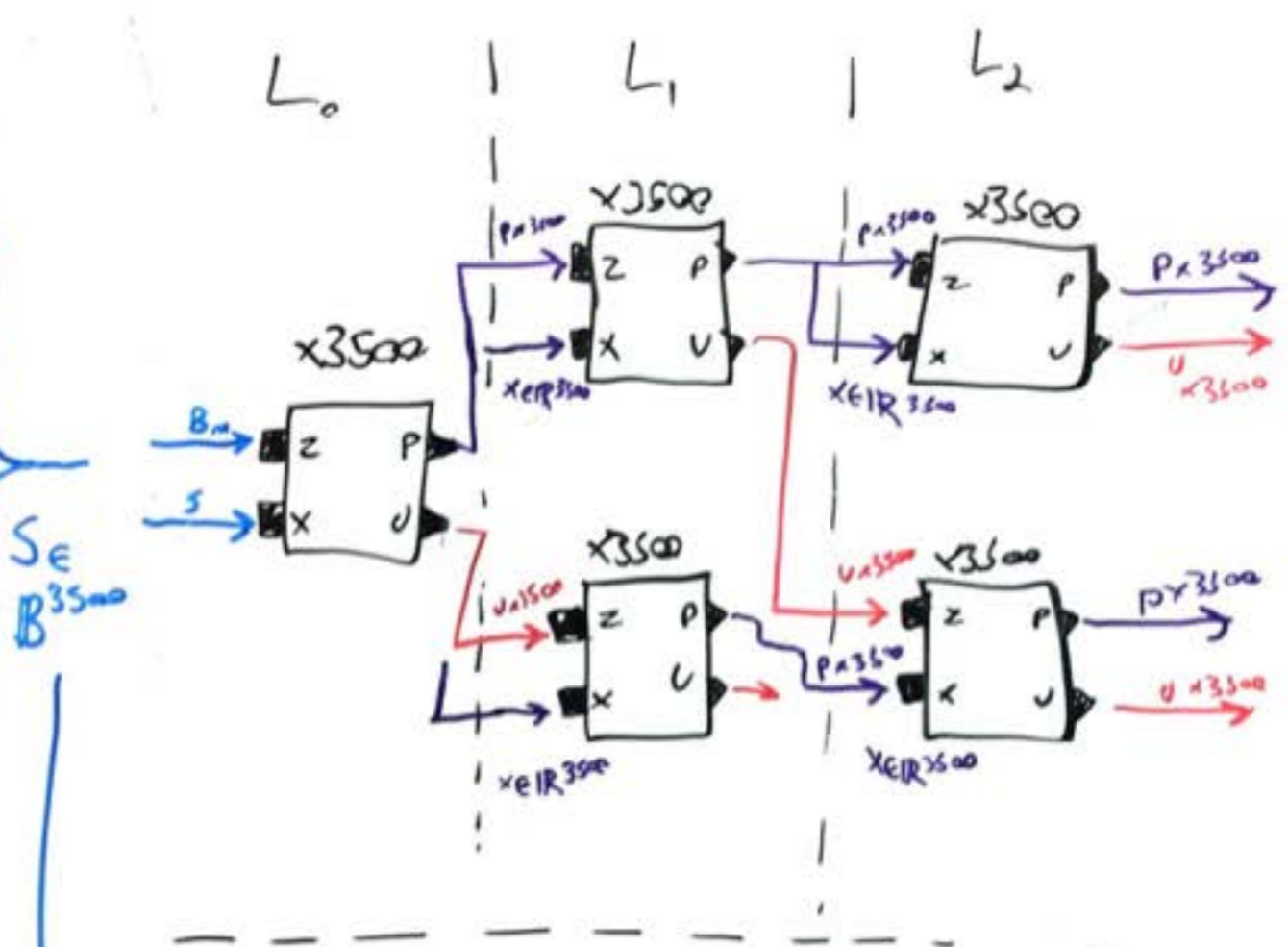
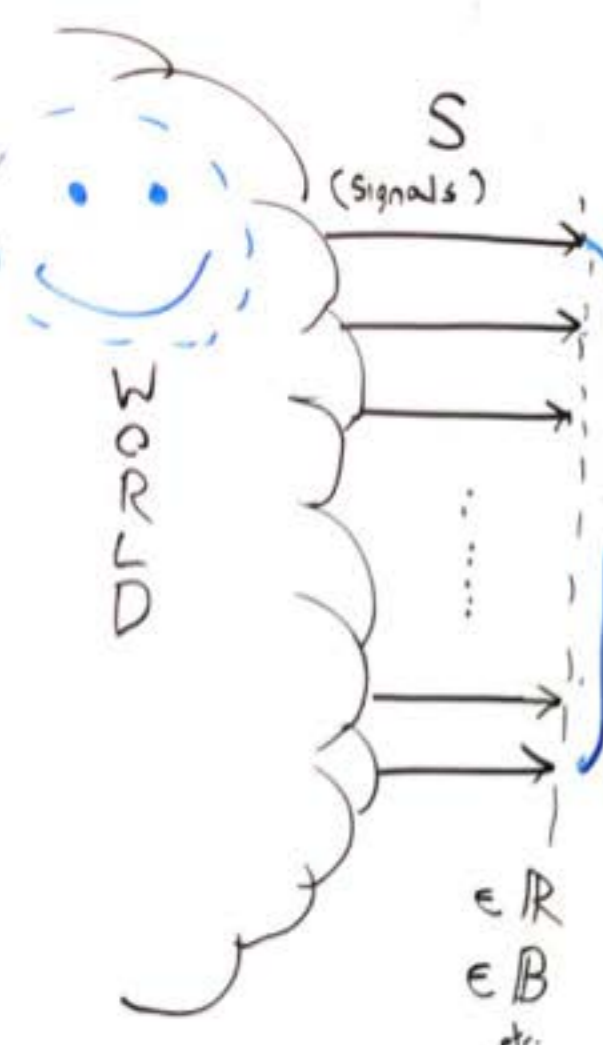

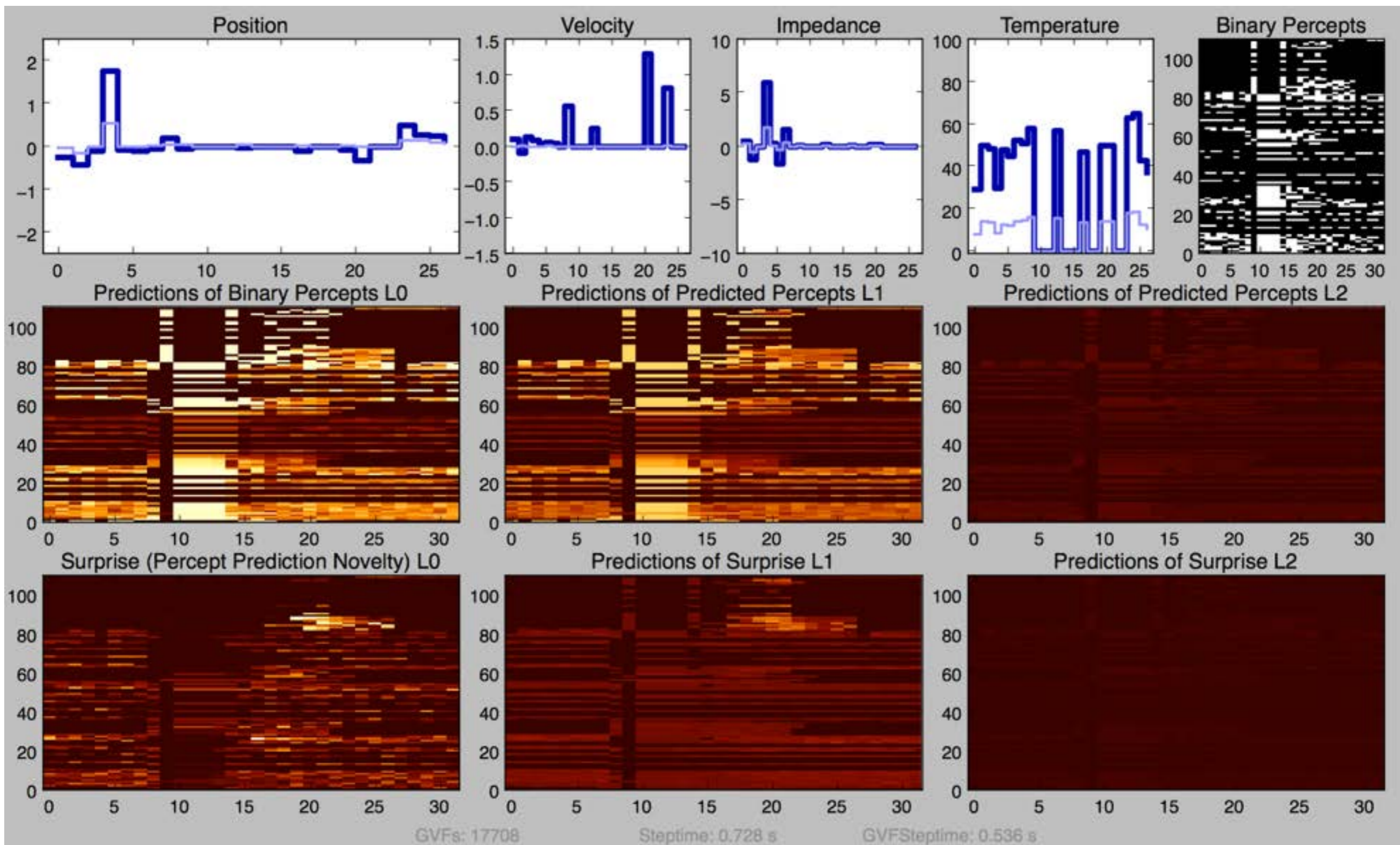

Horde on the MPL data stream: ~18k GVFs

Pilarski and Sherstan, *BioRob*, 2016.

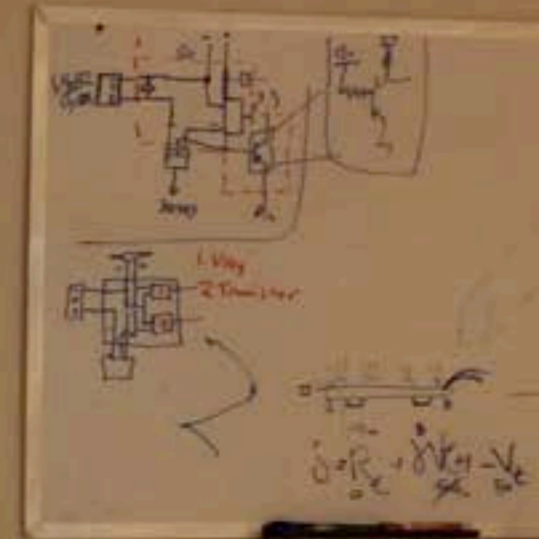

Pilarski Lab, Feb. 25, 2016
(Pilarski and Sherstan, *BioRob*, 2016)



Next steps:

Scaling up computation to scale up Horde. (2x14core CPU, 2xTeslaK40 GPU, 128GB RAM, 40TB storage, ...)

Target: 1 billion predictions a second.

More efficient code, better computer, **representation learning** via adaptive random representations (via Sutton 1993).

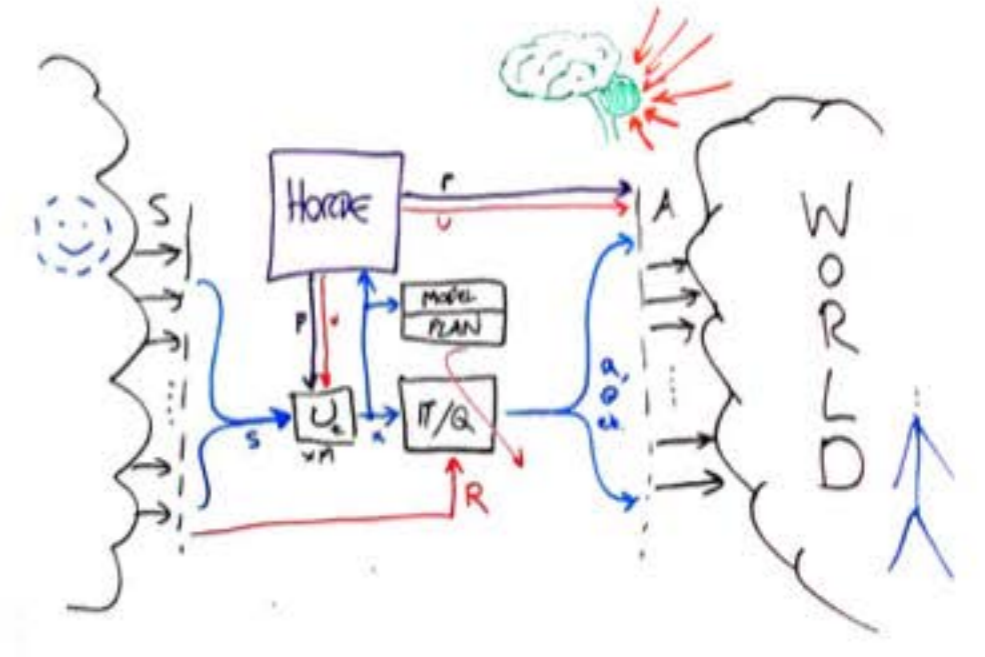
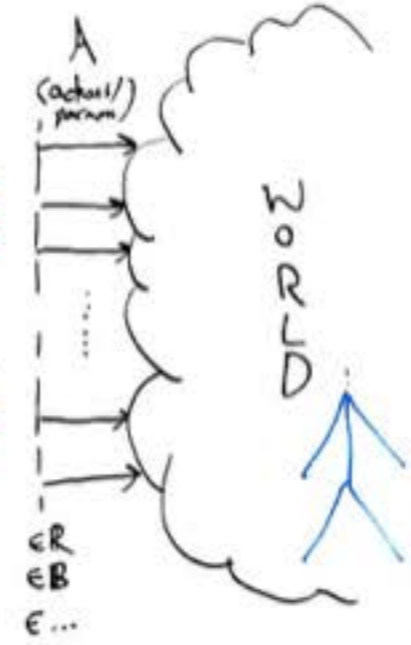
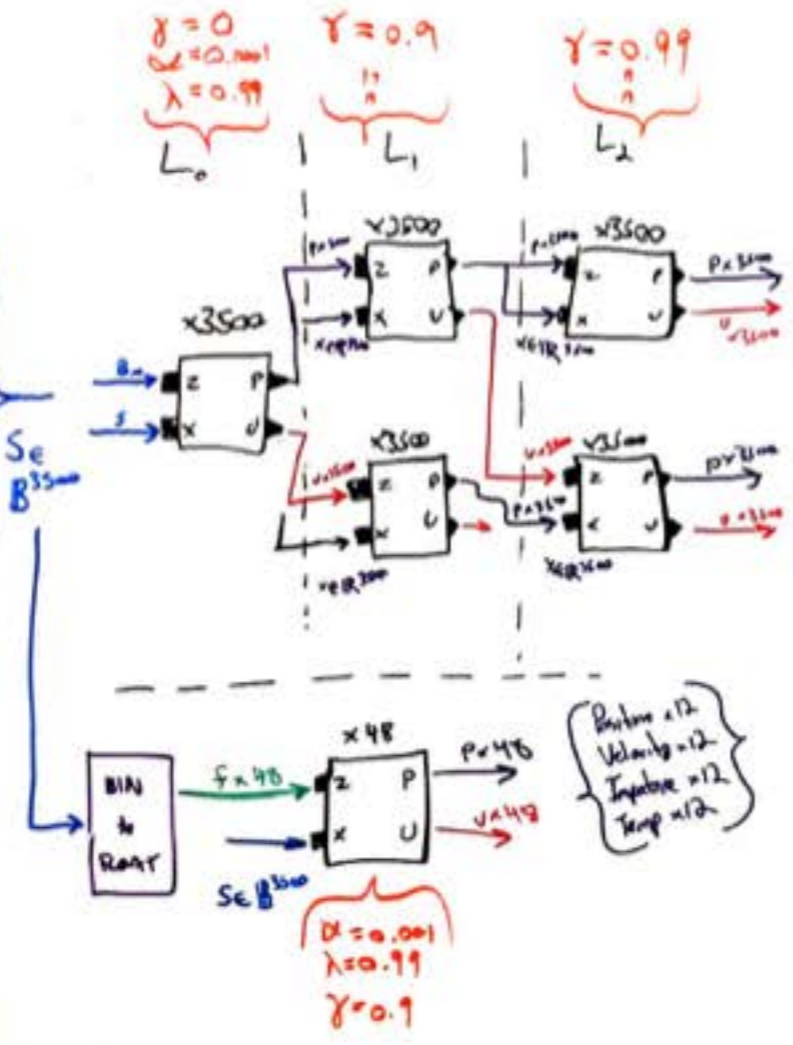
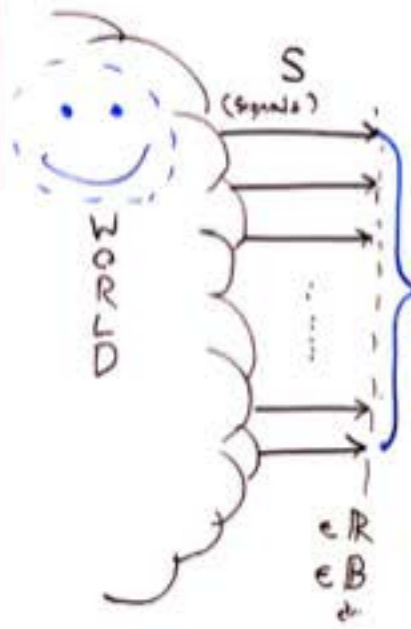

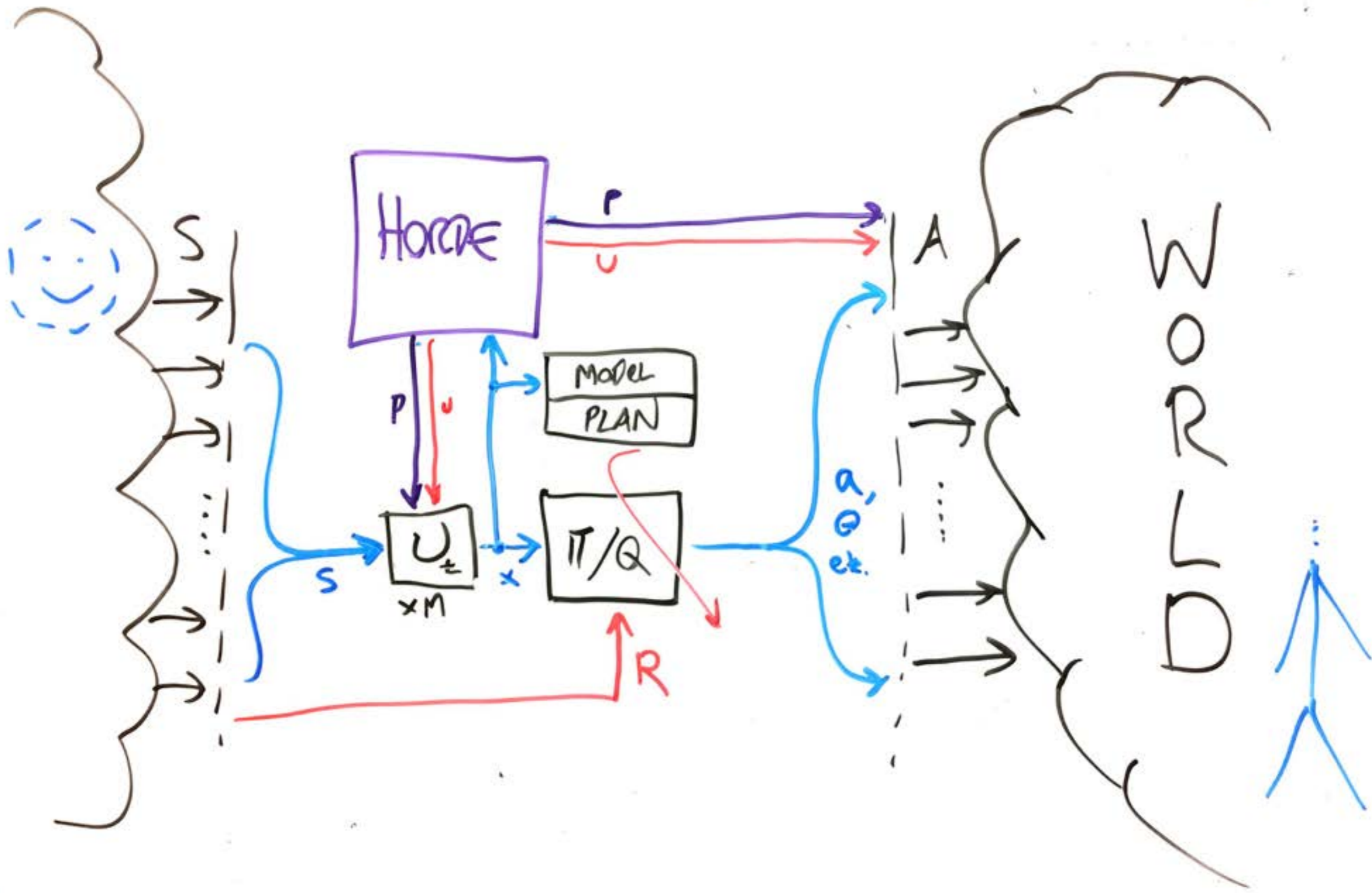

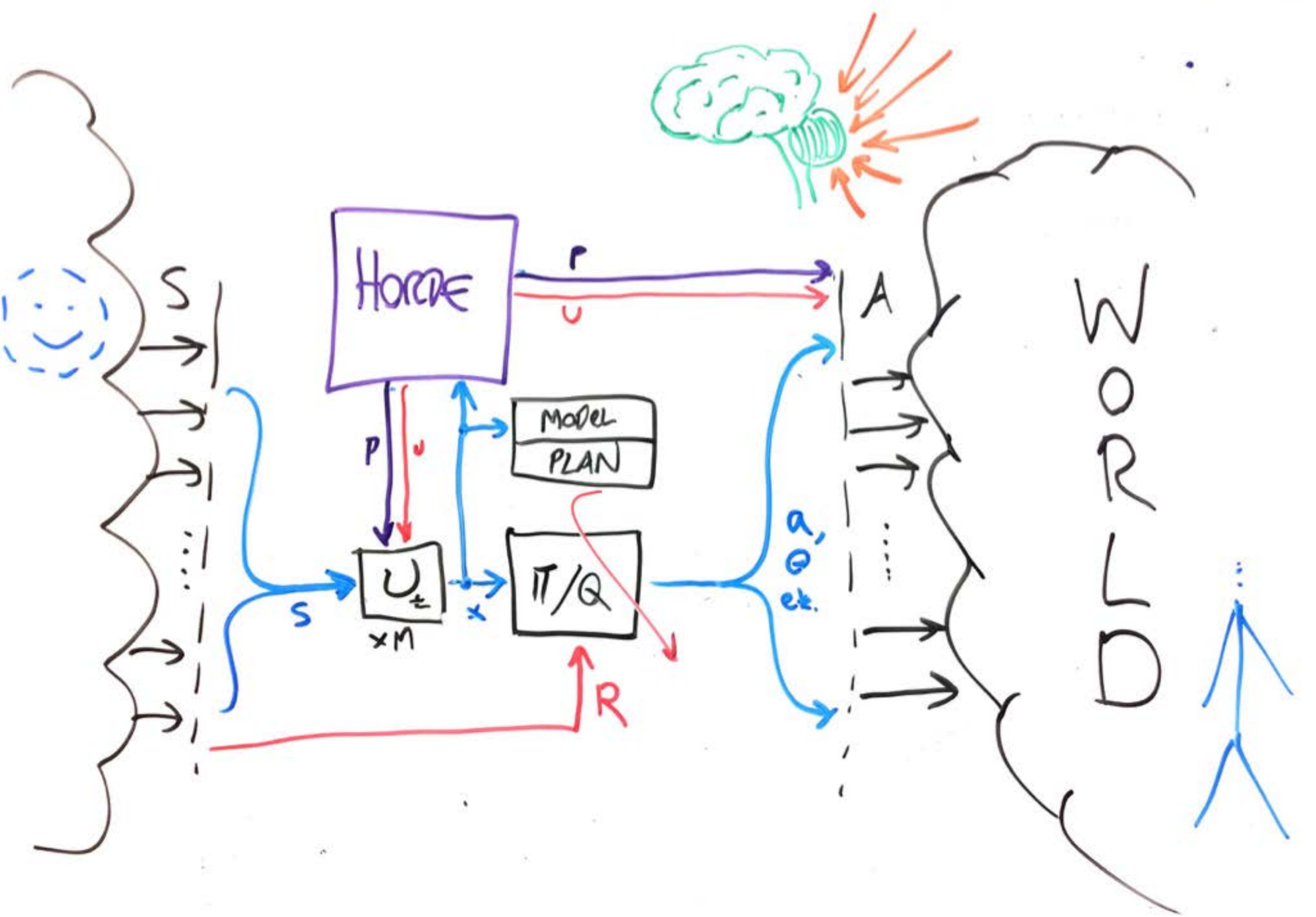

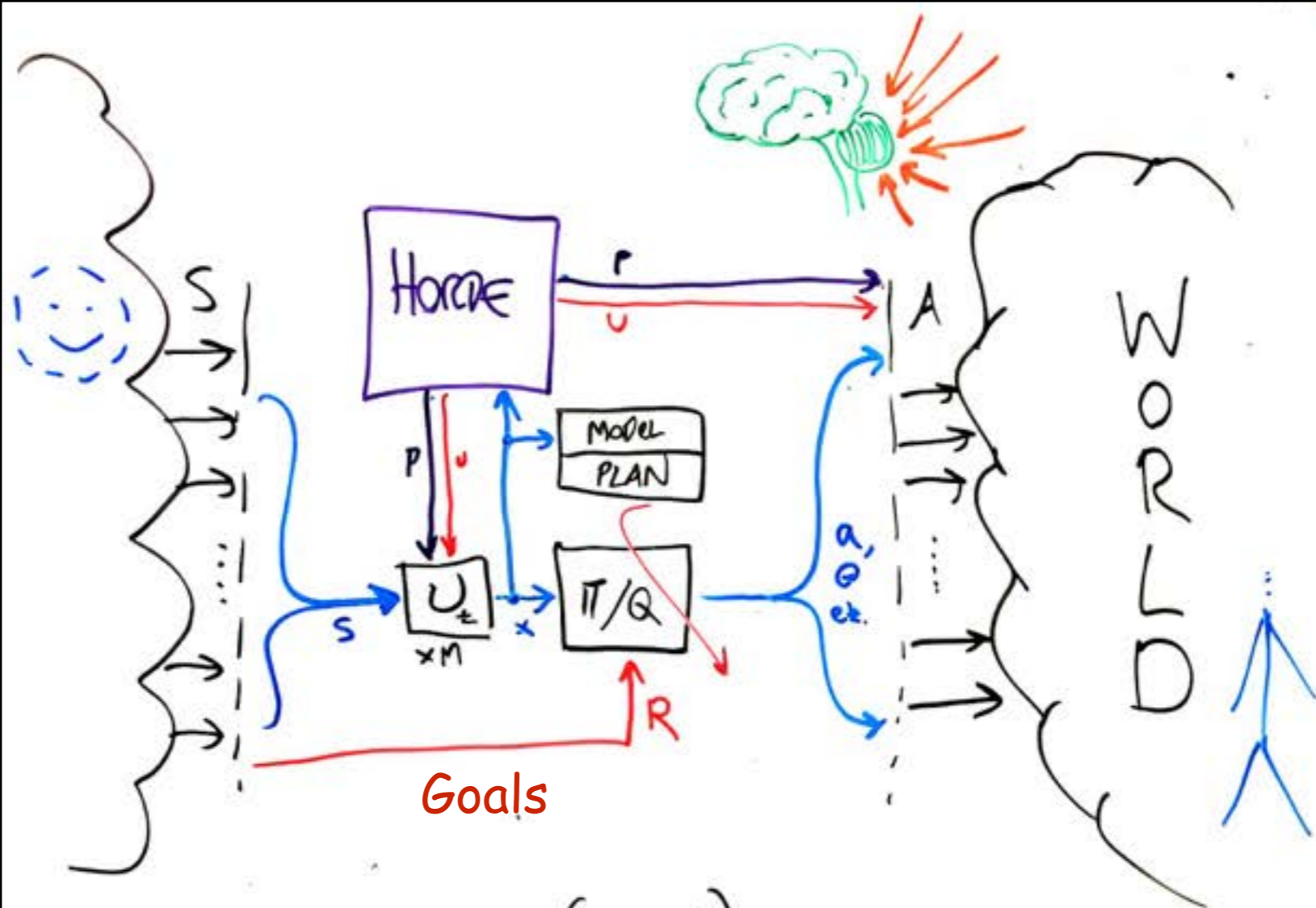



Goals

- Representation ($U_t \times M$)
- Prediction (Horde)
- Policy (Π/Q)
- Models, Planning
- Intentions (?) 
- Cute pictures of cats (?) 
(and dogs!)

