

Soft Sensor Development to Predict Melt Flow Index for a LDPE/EVA Plant



Rumana Sharmin, S. L. Shah and U. Sundararaj
Department of Chemical & Materials Engineering
University of Alberta

Outline

- Section 1
 - Introduction, motivation & objectives
- Section 2
 - Partial Least Squares Regression: Theory
- Section 3
 - Application & Results

What is a Soft-sensor ?

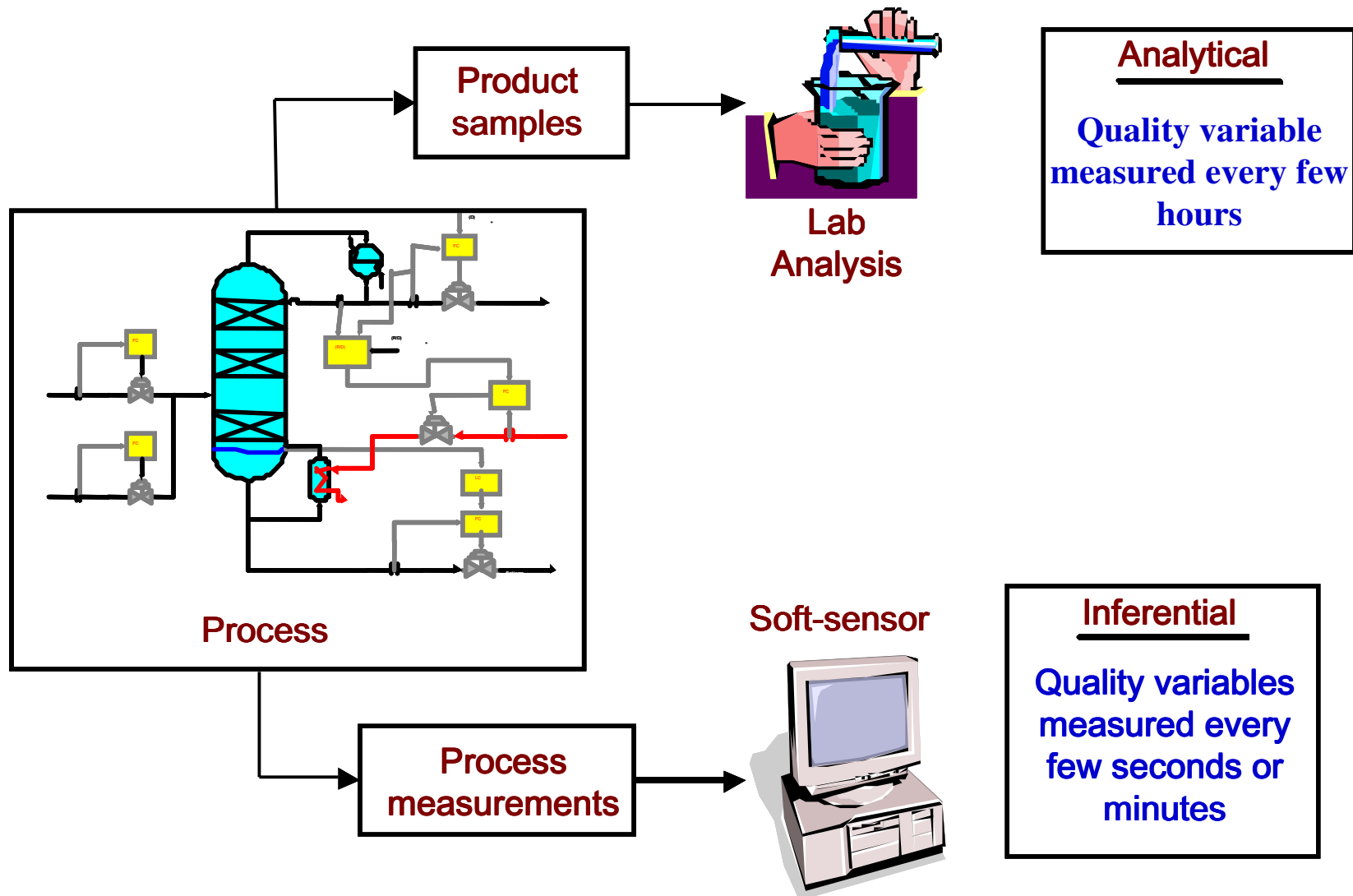

Polyethylene: Product Types

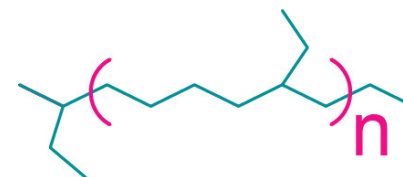
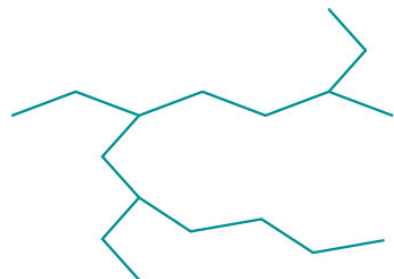

LDPE/(EVA)	HDPE	LLDPE
High pressure, high temperature free radical polymerization	Slurry and gas phase polymerization using catalyst at low pressure & temperature	Gas phase, solution or slurry process using Ziegler Natta, Phillips, or metallocene catalyst
0.915-0.94 gm/cm ³ (LDPE)	0.941-0.96 gm/cm ³	0.915-0.925gm/cm ³

Quality Control in Polyolefin Industry

- Product specifications for PE: given in terms of Melt Flow Index (MI)
- Online estimation of MI is time consuming
- First principles model to predict MI in real time for LDPE does not exist in open literature
 - Computer models for high-pressure LDPE reactors
 - Difficult to estimate Kinetic, physical, and thermodynamic parameters
 - No explicit relationship between the end use properties and the operating conditions
 - Models for HDPE/LLDPE not applicable for LDPE

Quality Control in Polyolefin Industry

- Neural Network based Inferential models have been built
 - Black box models with no physical insight
- Data based Multivariate Statistical Models were tested for **small scale simulation**
- Potential for large scale real process: being explored

Objectives and Methodology

- Build a soft-sensor model to predict MI of LDPE and EVA using routine operating data
- The model is intended to capture both steady state and transient behavior
- Method: Data based Partial Least Squares Regression (PLS)

Partial Least Squares: Key Idea

- Convert the MIMO regression problem into a series of SISO regression problem
- Piece the results of the SISO regression problems together to arrive at the result for the MIMO problem

PLS Modeling (Cont..)

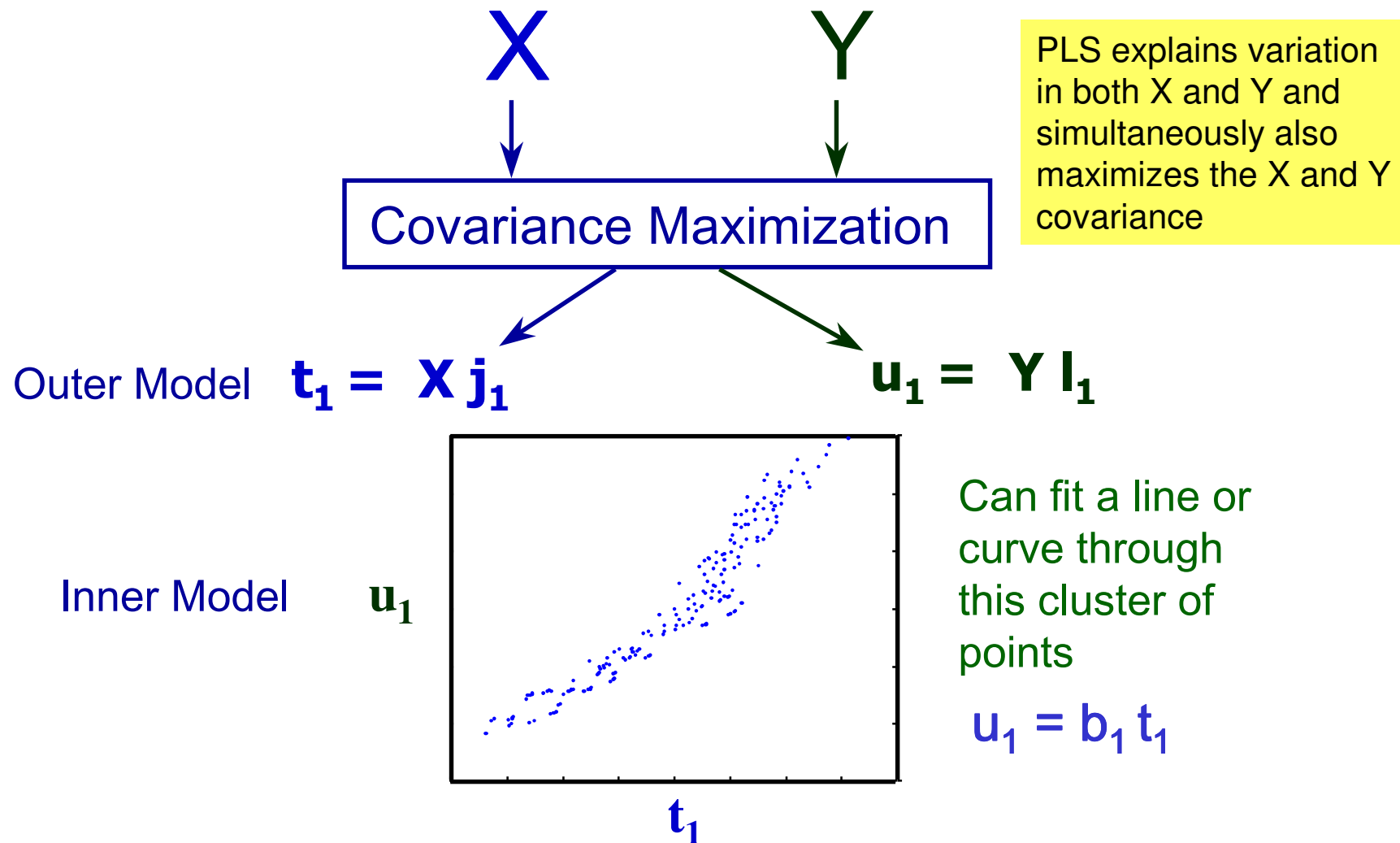

Summary: PLS Modeling

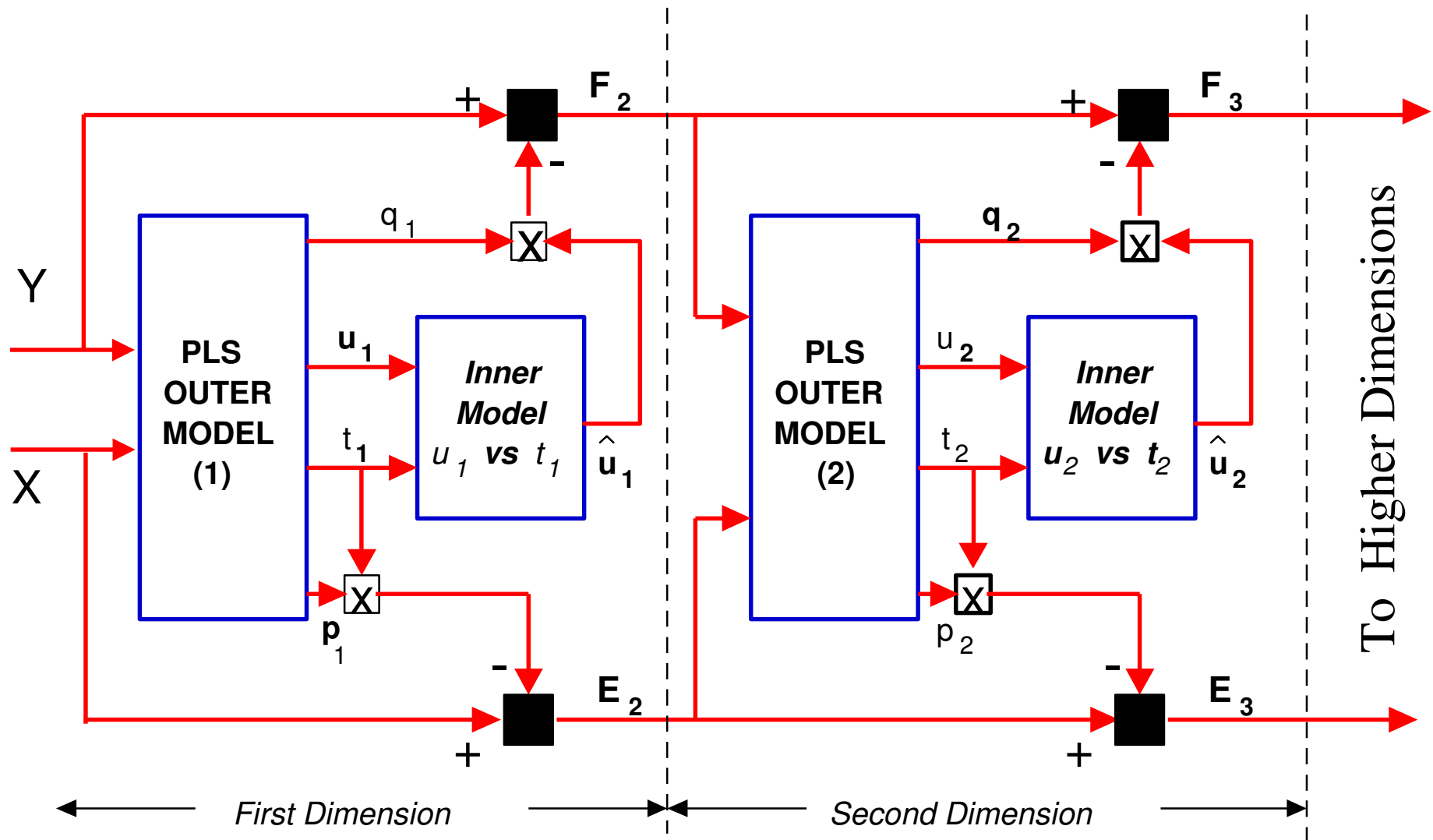

Scenario at AT Plastics

- 26+ grades of LDPE and EVA copolymers using high-pressure free radical polymerization
- 2 types of MI measurements
 - off-line lab analysis on irregular basis
 - Estimation using online rheometer
 - Multiple steady state inferential models used to convert rheometer readings into MI for individual grades
 - Estimates during grade transition is often unreliable
- Plant Target: online MI sensor for steady and transient operation

5R Polymerization Unit

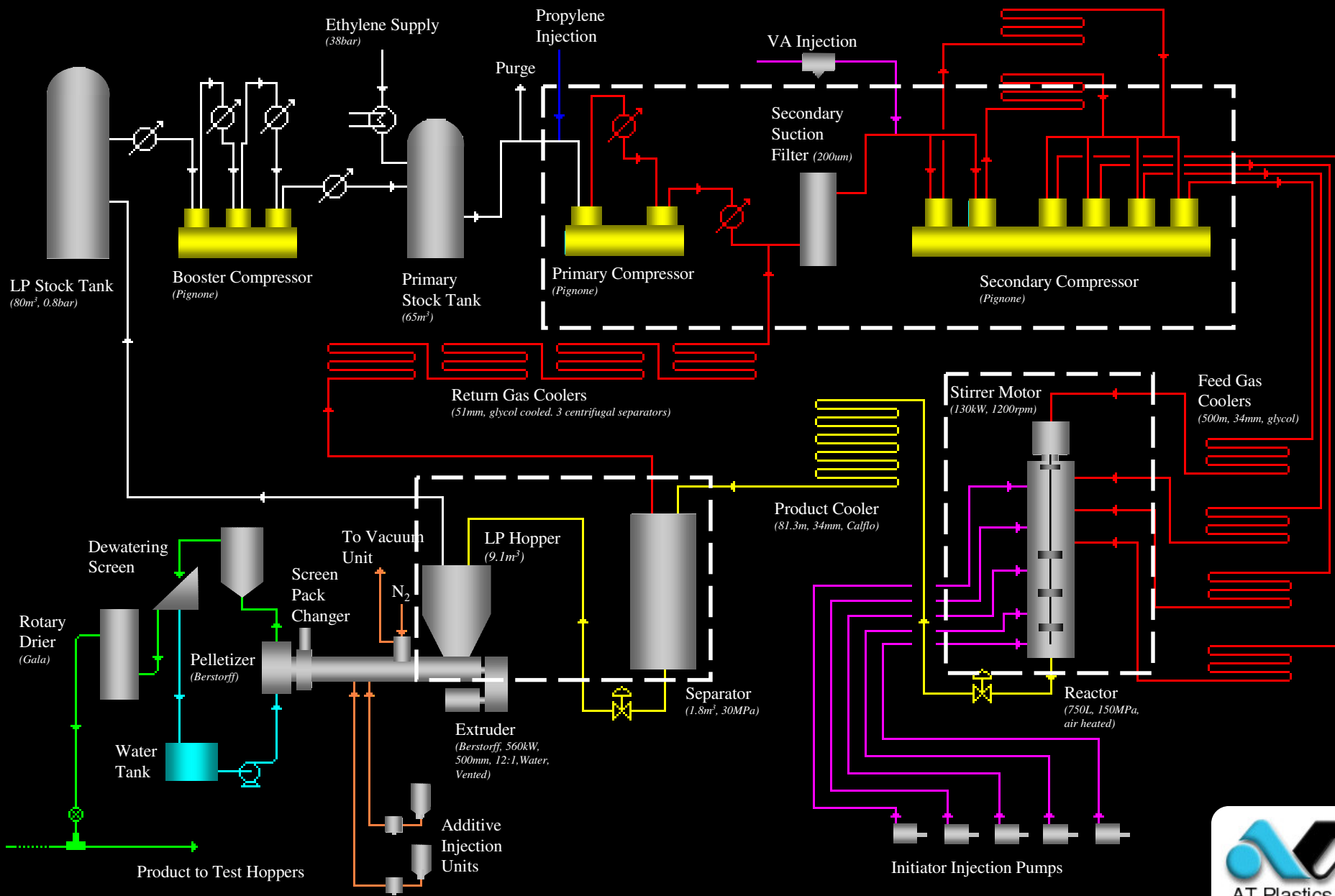

Procedure for Softsensor Design

- Data Collection
- Data Preprocessing
 - Check for Data Compression
 - Outlier detection and filtering
 - Calculation of mass flow rate through reactor
 - Selection of melt index values
 - Selection of appropriate inputs
 - Estimation of transport delay
- PLS modeling

PLS Modeling

- Range of MI: $0 < MI < 2000$
- Strategy:
 - divide entire range of MI into a number of clusters
 - build one model for each cluster
- Model structure:

$$MI(t) = a_1 x_1 (t - t_{d_1}) + a_2 x_2 (t - t_{d_2}) \dots a_n x_n (t - t_{d_n})$$

Prediction: Low MI range

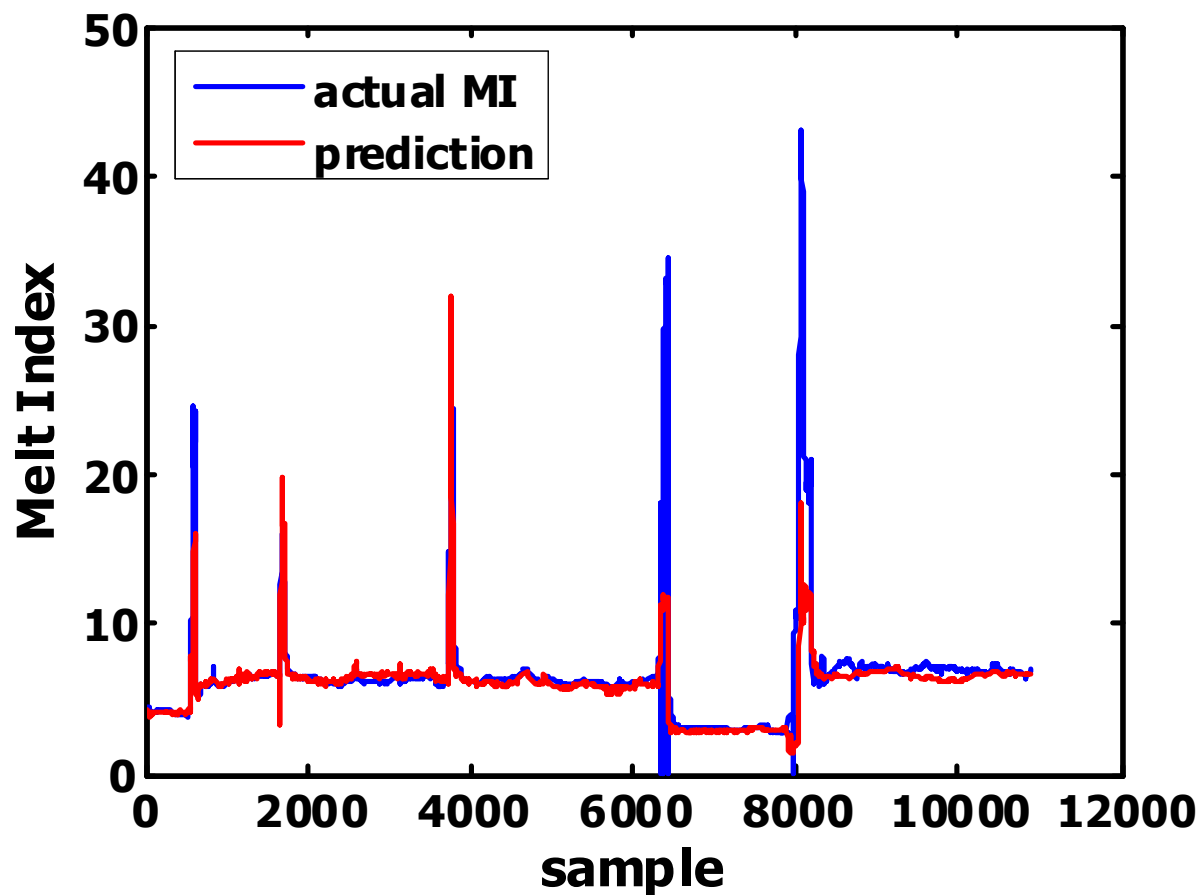

Prediction: High MI range

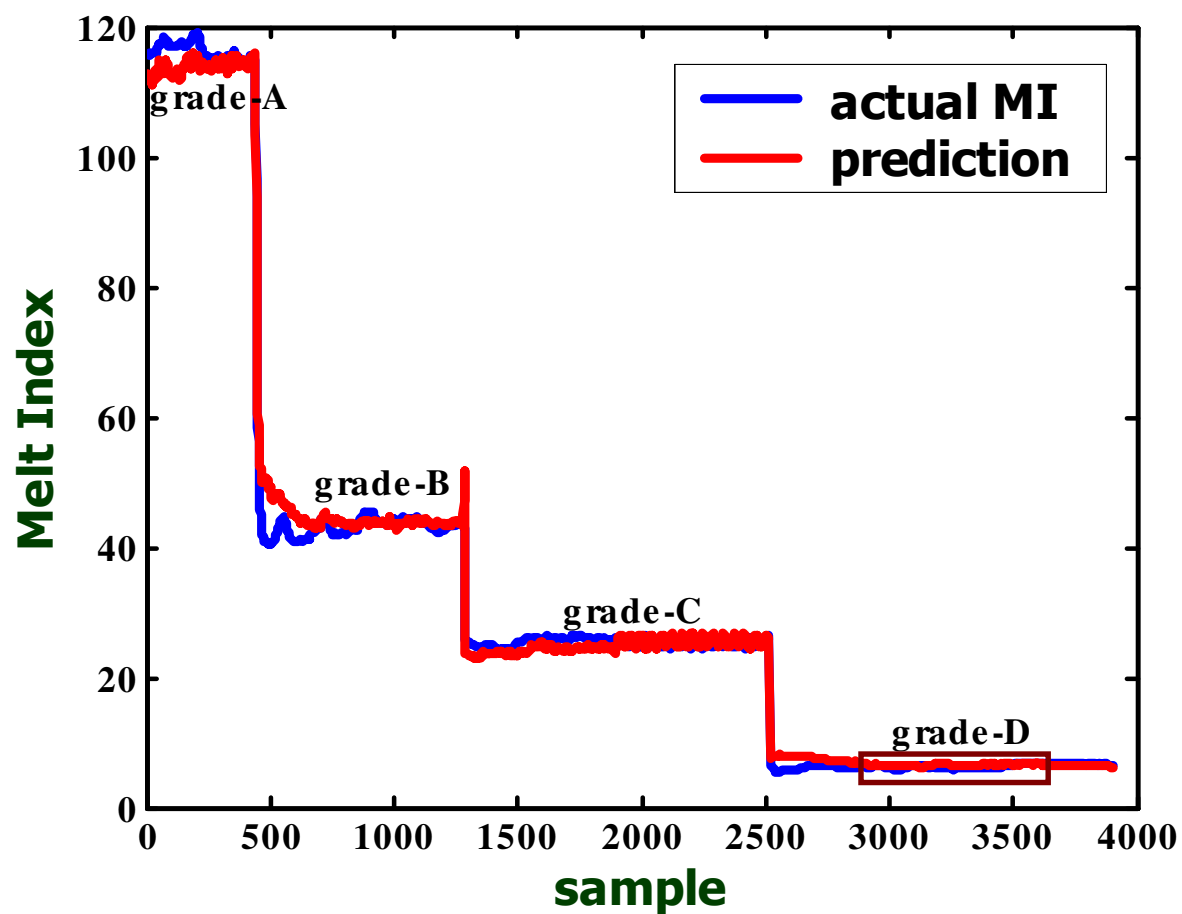

Prediction: High MI range

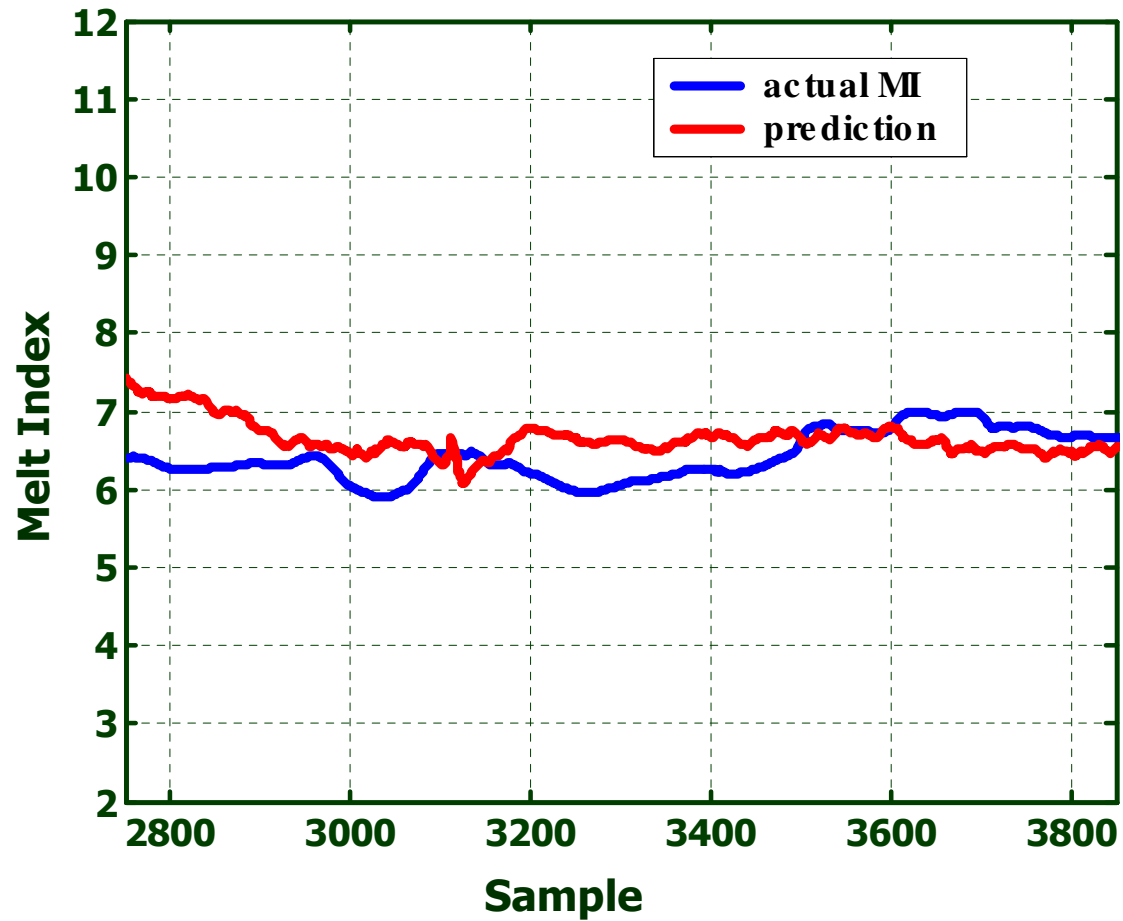

Prediction: Single grade model

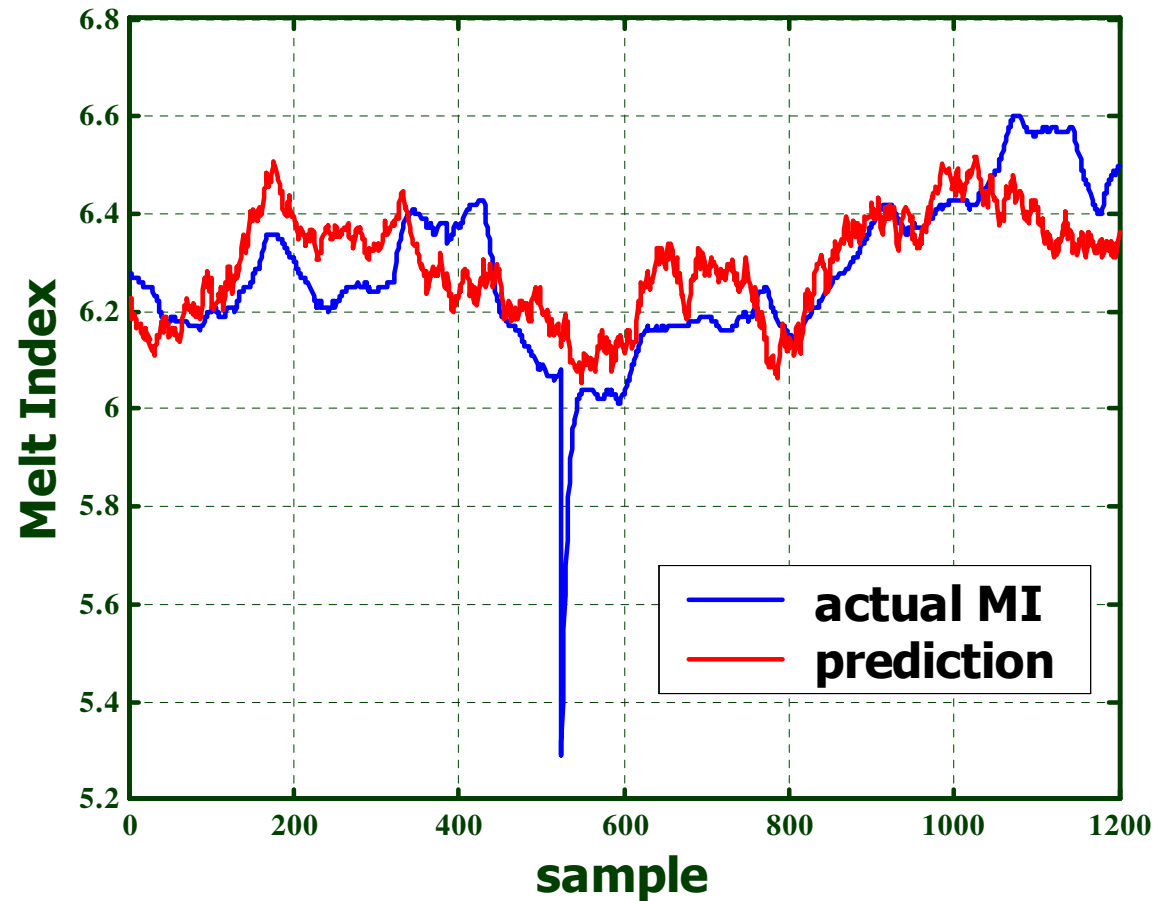

Model Validation: Need for Adapting

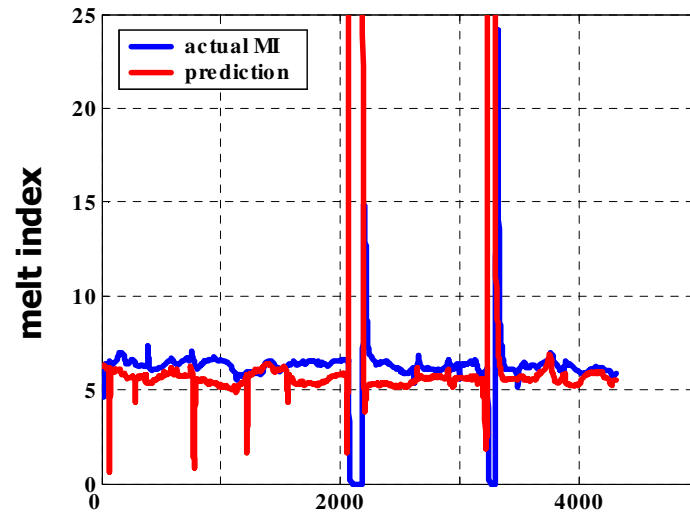

After 4 months

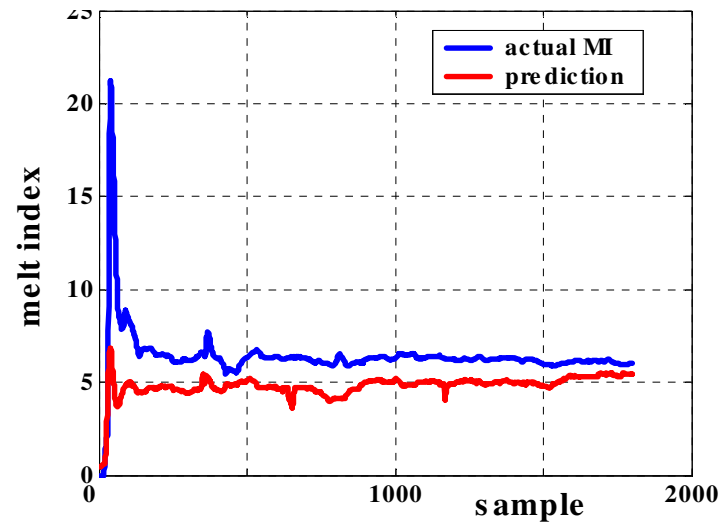

After 15 months

Key Idea for Implementation

- Build an initial PLS model with initial set of data X and Y
- Select window size N , collect next N samples, while using the initial model for prediction. Denote the data collected during N sample is X_1 and Y_1
- Formulate

$$X = \begin{bmatrix} P^T \\ X_1 \end{bmatrix}, Y = \begin{bmatrix} BQ^T \\ Y_1 \end{bmatrix}$$

- Build PLS model using updated X and Y . Use this new model for prediction in the next window of samples

(Ref: Qin, S.J., Computers Chem. Engg. **22**, 4/5, 503-514, 1998)

Recursive PLS: Application

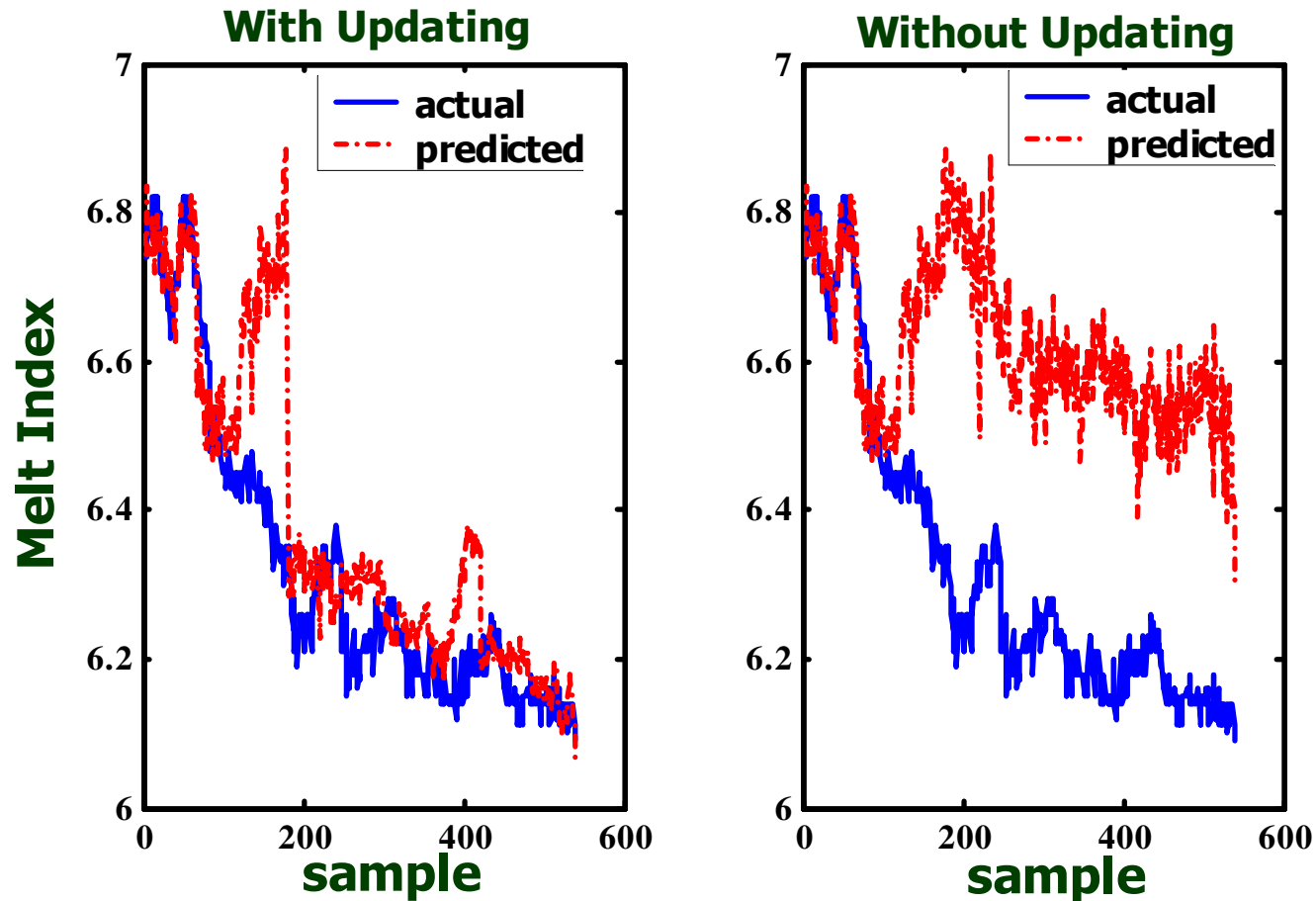

Conclusions

- Melt Flow Index can be predicted for LDPE and EVA polymers using PLS regression method
- Universal model can predict the steady state and transient behavior of the output for certain ranges of melt index
- PLS models for single grades show better prediction
- Recursive updating improved model performance

Acknowledgement

- AT Plastics
- Alberta Ingenuity Fund
- Computer Process Control group at U of A